

CMI-CDSS3015NH-SERIES

Features

- ▶ High current and low profile.
- ▶ Available tape and reel for auto insertion
- ▶ Simple and Shield structure.
- ▶ RoHS compliant
- ▶ Halogen-Free
- ▶ AEC-Q200 qualified

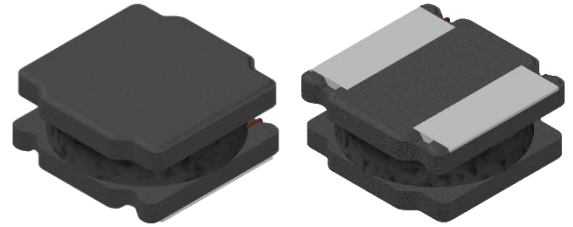

Applications

- ▶ Equipment using for automobiles
(ECM, Airbags, Headlights, Electronic Powder Steering, Motors, ABS, other)

Dimension (Unit:mm)

Land Pattern (Unit:mm)

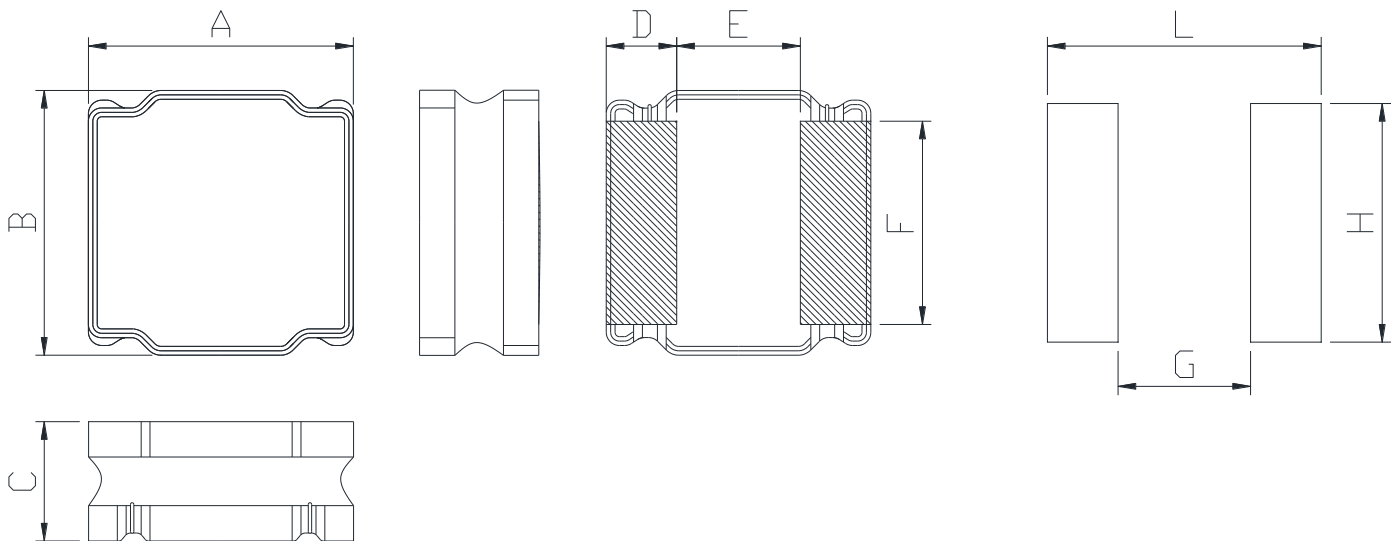

A	B	C	D	E	F	G	H	L
3.0±0.2	3.0±0.2	1.5 Max.	0.75±0.2	1.5±0.2	2.4±0.3	1.5	2.7	3.1

Regulation of part number

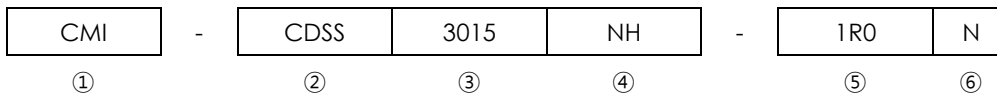

- ① CoilMaster's initial
- ② Series Name : Car Drum Core Square shape Silver paste type Power inductor
- ③ Core Size (unit:mm)
- ④ Material
- ⑤ Typical inductance value (1.0 uH)
- ⑥ Inductance tolerance ($\pm 20\%$)

Specifications

Part Number	Inductance (uH)	Tolerance (\pm)	DCR(m Ω) $\pm 30\%$	Isat(A) Max.	Itemp(A) Max.	Test Frequency (Hz)
CMI-CDSS3015NH-1R0N	1.0	30%	39	2.32	2.35	100K
CMI-CDSS3015NH-1R2N	1.2	30%	40	2.21	1.95	100K
CMI-CDSS3015NH-1R5N	1.5	30%	50	2.00	1.70	100K
CMI-CDSS3015NH-1R8N	1.8	30%	50	1.75	1.70	100K
CMI-CDSS3015NH-2R2N	2.2	30%	60	1.60	1.60	100K
CMI-CDSS3015NH-3R3M	3.3	20%	80	1.32	1.36	100K
CMI-CDSS3015NH-4R7M	4.7	20%	125	1.10	1.09	100K
CMI-CDSS3015NH-6R8M	6.8	20%	200	0.85	0.85	100K
CMI-CDSS3015NH-100M	10	20%	250	0.72	0.77	100K
CMI-CDSS3015NH-120M	12	20%	320	0.70	0.68	100K
CMI-CDSS3015NH-150M	15	20%	350	0.66	0.65	100K
CMI-CDSS3015NH-180M	18	20%	430	0.56	0.59	100K
CMI-CDSS3015NH-220M	22	20%	460	0.52	0.57	100K
CMI-CDSS3015NH-330M	33	20%	820	0.44	0.43	100K
CMI-CDSS3015NH-470M	47	20%	1250	0.33	0.35	100K
CMI-CDSS3015NH-101M	100	20%	2300	0.23	0.21	100k

- Isat: When based on the inductance change rate (Approximately 30% below in the initial value)
- Itemp: When based on the temperature increase (Temperature increase of approximately 40°C by self heating)
- Operating Temperature Range (including self temperature) : -40°C ~ +125 °c

▪ **You can also contact us by e-mail : coilmaster@coilmaster.com**

- All specifications are subject to change without notice.
- Update date : 2022.03.15

Packaging

(1) Package quantity : 2,000 (pcs/reel)

(2) Reel Dimensions (unit:mm)

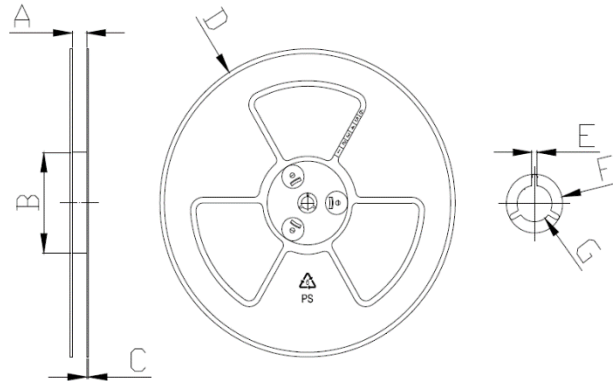

A	B	C	D	E	F	G
9.00	60.0	0.90	178.0	2.70	20.70	13.00
+0.50	+0.50	+0.50	+1.00	+0.30	+0.80	+0.40
-0.50	-0.50	-0.50	-1.00	-0.30	-0.80	-0.40

(3) Tape Dimensions

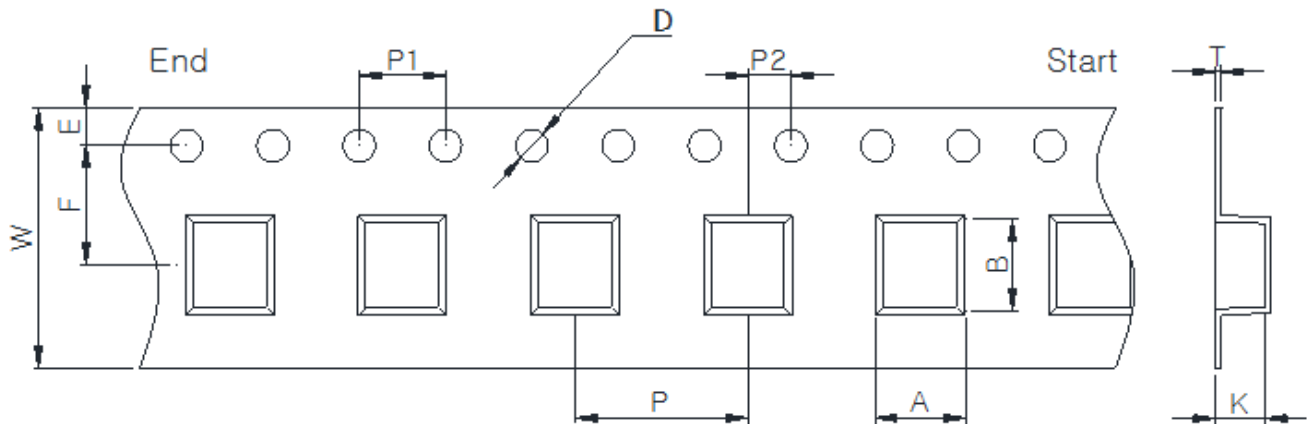

W	A	B	K	E	F	P	P1	P2	D	T
8.00	3.30	3.30	1.90	1.75	3.50	4.00	4.00	2.00	1.50	0.25
+0.30	+0.05	+0.05	+0.05	+0.10	+0.05	+0.10	+0.10	+0.05	+0.10	+0.05
-0.30	-0.05	-0.05	-0.05	-0.10	-0.05	-0.10	-0.10	-0.05	-0.00	-0.05

Korea Sales Office (KOREA) +82)31-904-1444
 China Sales Office (CHINA) +86)0758-683-1444
 Hungary Sales office (EUROPE) +36)1-404-5832

H.K Sales Office (HONGKONG) +852)2711-5551
 LA Sales Office (USA) +1)714-616-6989

• You can also contact us by e-mail : coilmaster@coilmaster.com

- All specifications are subject to change without notice.
- Update date : 2022.03.15

www.coilmaster.com