

# CME-CSCF4532L-201T10

## Features

- ▶ High common mode impedance at high frequency effects  
Excellent noise suppression performance.
- ▶ Realizes small size and low profile.
- ▶ RoHS compliant.
- ▶ High reliability test meet AEC-Q200.

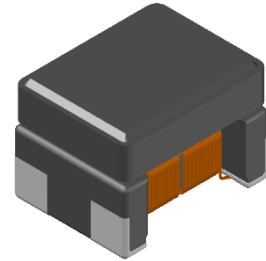

## Applications

- ▶ Ethernet system.

## Dimension (Unit:mm)

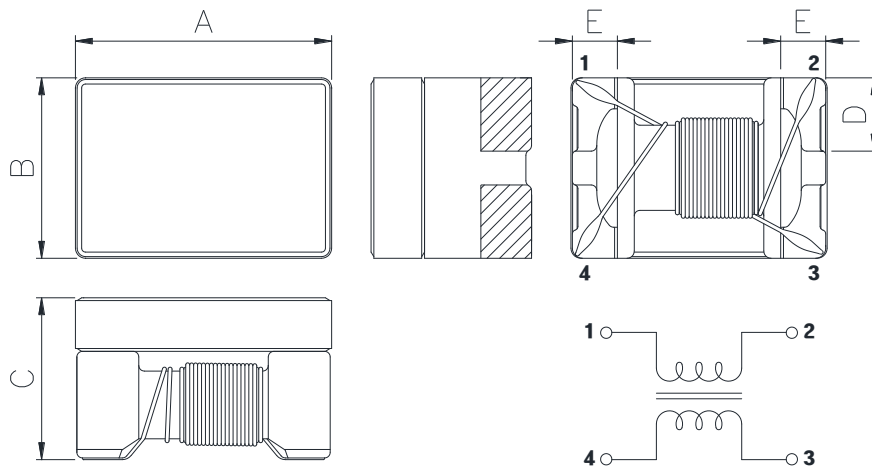

## Land Pattern (Unit:mm)

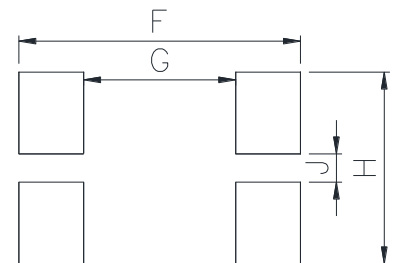

A	B	C	D	E	F	G	H	J
4.5 ±0.2	3.2 ±0.2	2.8 ±0.2	1.3 ±0.2	0.8 ±0.2	5.0	2.7	3.4	0.5

## Regulation of part number

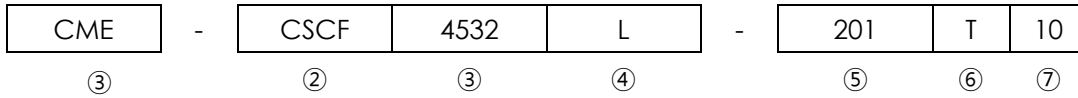

- ① CoilMaster's initial
- ② Series Name : Car Signal Line Common mode Filter
- ③ Core Size (unit:mm)
- ④ Type
- ⑤ Common mode inductance value (200uH)
- ⑥ Packing type
- ⑦ Rated Current

## Specifications

Part Number	Common Mode Inductance (μH)	Common Mode Inductance Tolerance	DCR (Ω) Max.	Rated Current (mA) Max.	Insulation Resistance (MΩ) Min.	Rated Voltage (V) Max.
CME-CSCF4532L-201T10	200	+50/-20%	4.5	100	10	50

- Inductance test condition : 100 kHz
- Operating Temperature Range : -40°C ~ +150 °C

## Impedance VS Frequency characteristics

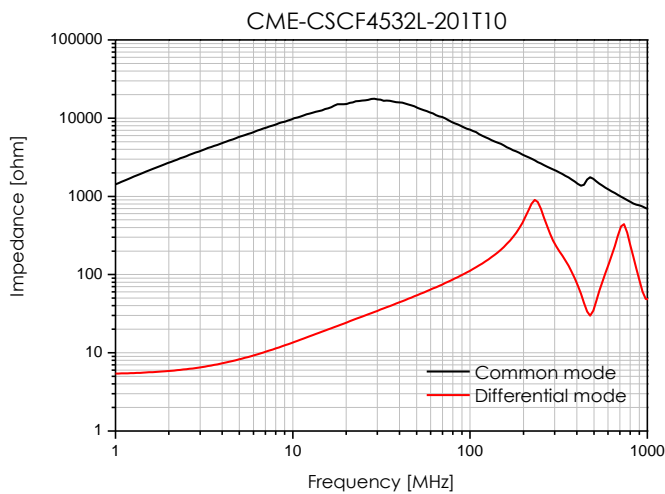

- You can also contact us by e-mail : [coilmaster@coilmaster.com](mailto:coilmaster@coilmaster.com)
- All specifications are subject to change without notice.
- Update date : 2024.02.20

## Packaging

(1) Package quantity : 2,500 (pcs/reel)

(2) Reel Dimensions (unit:mm)

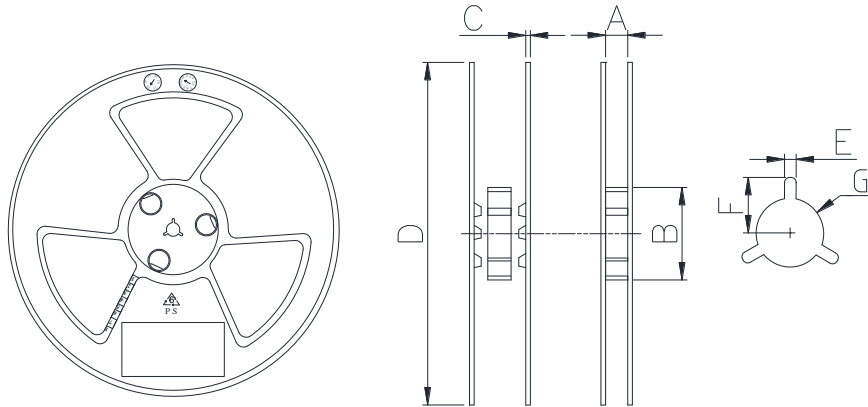

A	B	C	D	E	F
12.50	100.0	2.30	330.0	2.30	10.75
+0.50	+1.00	+0.20	+3.00	+0.30	+0.30
-0.50	-1.00	-0.20	-3.00	-0.30	-0.30

(3) Tape Dimensions

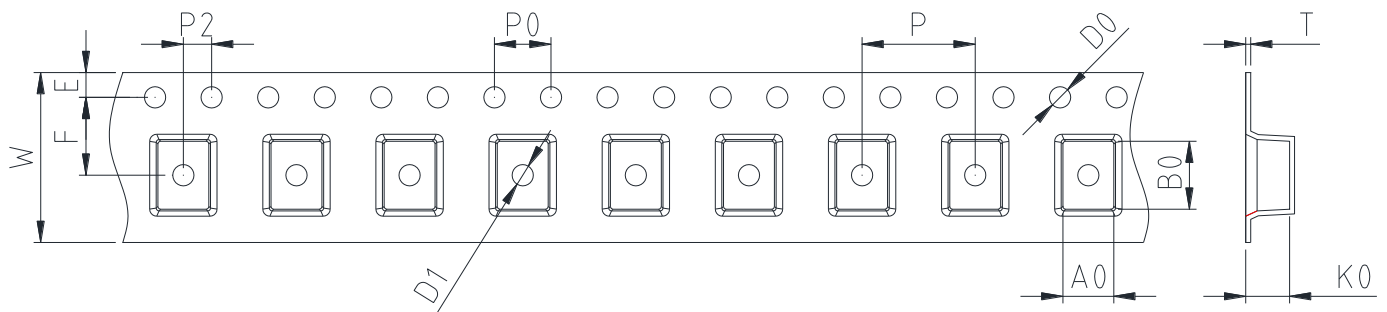

W	A0	B0	K0	E	F	P	P0	P2	D0/D1	T
12.00	3.60	4.80	3.10	1.75	5.50	8.00	4.00	2.00	1.50	0.35
+0.30	+0.10	+0.10	+0.10	+0.10	+0.10	+0.10	+0.10	+0.10	+0.10	+0.05
-0.10	-0.10	-0.10	-0.10	-0.10	-0.10	-0.10	-0.10	-0.10	-0.00	-0.05

Korea Sales Office (KOREA) +82)31-904-1444  
 China Sales Office (CHINA) +86)0758-683-1444  
 Hungary Sales office (EUROPE) +36)1-404-5832

H.K Sales Office (HONGKONG) +852)2711-5551  
 LA Sales Office (USA) +1)714-616-6989

• You can also contact us by e-mail : [coilmaster@coilmaster.com](mailto:coilmaster@coilmaster.com)

- All specifications are subject to change without notice.
- Update date : 2024.02.20

[www.coilmaster.com](http://www.coilmaster.com)