

# CMI-CDSS8040NH-SERIES

## Features

- ▶ High current and low profile.
- ▶ Available tape and reel for auto insertion
- ▶ Simple and Shield structure.
- ▶ RoHS compliant
- ▶ Halogen-Free
- ▶ AEC-Q200 qualified.

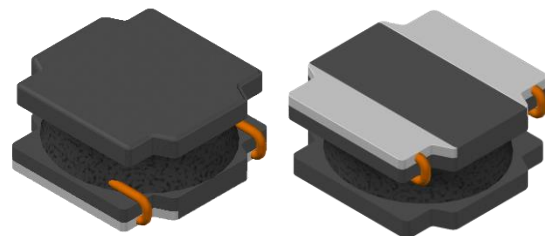

## Applications

- ▶ Car navigation, car stereo and car accessories only  
(Not available for use related to driving, curving, stopping, and the other safety.)

## Dimension (Unit:mm)

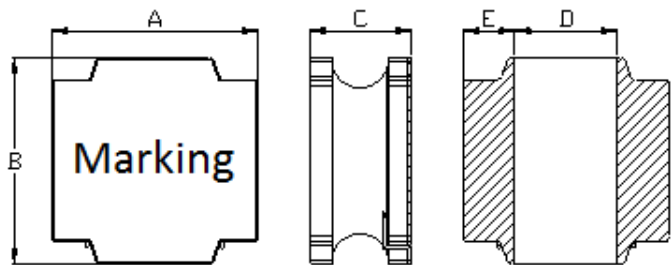

A	B	C	D	E
8.0 ±0.3	8.0 ±0.3	4.2 Max.	2.1 ±0.3	3.8 ±0.3

## Land Pattern (Unit:mm)

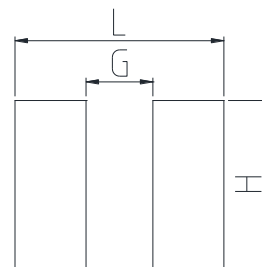

L	G	H
8.2	3.8	7.5

## Regulation of part number

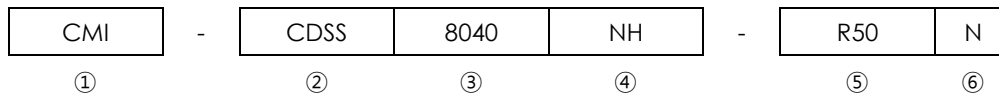

- ① CoilMaster's initial
- ② Series Name : Car Drum Core Square shape Silver paste type Power inductor
- ③ Core Size (unit:mm)
- ④ Material
- ⑤ Typical inductance value (0.50 uH)
- ⑥ Inductance tolerance ( $\pm 30\%$ )

## Specifications

Part Number	Inductance (uH)	Tolerance ( $\pm$ )	DCR(m $\Omega$ ) $\pm 30\%$	Isat(A) Max.	Itemp(A) Max.	Test Frequency (Hz)
CMI-CDSS8040NH-R50N	0.50	30%	7	12.00	10.00	100k
CMI-CDSS8040NH-R82N	0.82	30%	8	13.80	6.30	100k
CMI-CDSS8040NH-1R0N	1.0	30%	8	9.85	6.30	100k
CMI-CDSS8040NH-1R5N	1.5	30%	10	8.15	5.65	100k
CMI-CDSS8040NH-2R2N	2.2	30%	12	7.10	5.15	100k
CMI-CDSS8040NH-3R3N	3.3	30%	17	6.50	4.40	100k
CMI-CDSS8040NH-3R6N	3.6	30%	17	6.50	4.20	100k
CMI-CDSS8040NH-4R7N	4.7	30%	19	5.90	4.10	100k
CMI-CDSS8040NH-6R8M	6.8	20%	24	4.55	3.60	100k
CMI-CDSS8040NH-8R2M	8.2	20%	26	4.20	3.45	100k
CMI-CDSS8040NH-100M	10	20%	42	3.60	3.30	100k
CMI-CDSS8040NH-150M	15	20%	47	2.95	2.60	100k
CMI-CDSS8040NH-180M	18	20%	53	2.70	2.40	100k
CMI-CDSS8040NH-220M	22	20%	69	2.40	2.10	100k
CMI-CDSS8040NH-330M	33	20%	97	2.05	1.80	100k
CMI-CDSS8040NH-470M	47	20%	136	1.75	1.55	100k
CMI-CDSS8040NH-560M	56	20%	170	1.55	1.40	100k
CMI-CDSS8040NH-680M	68	20%	196	1.45	1.25	100k
CMI-CDSS8040NH-820M	82	20%	225	1.30	1.15	100k
CMI-CDSS8040NH-101M	100	20%	290	1.15	1.00	100k
CMI-CDSS8040NH-121M	120	20%	334	1.05	0.95	100k

• You can also contact us by e-mail : [coilmaster@coilmaster.com](mailto:coilmaster@coilmaster.com)

- All specifications are subject to change without notice.
- Update date : 2024.07.25



## Packaging

(1) Package quantity : 3,000 (pcs/reel)

(2) Reel Dimensions (unit:mm)

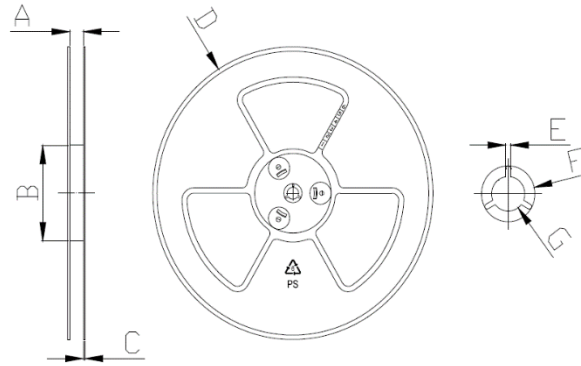

A	B	C	D	E	F	G
16.50	100.0	2.00	330.0	2.30	21.50	13.00
+0.50	+1.00	+0.10	+3.00	+0.30	+0.30	+0.50
-0.50	-1.00	-0.10	-3.00	-0.30	-0.30	-0.20

(3) Tape Dimensions

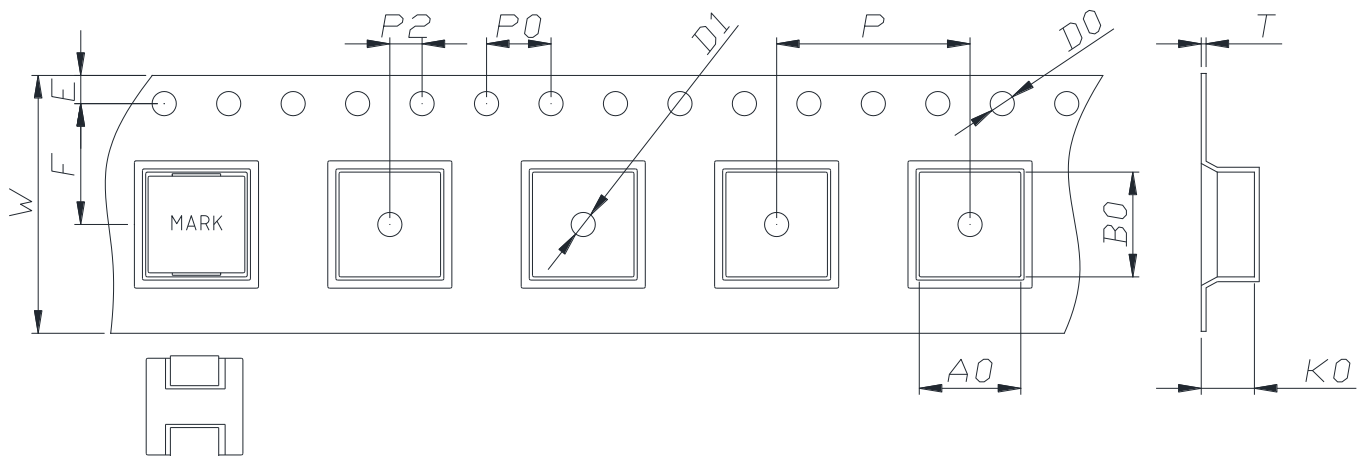

W	A0	B0	K0	E	F	P	P0	P2	D0/D1	T
16.00	7.00	7.50	1.70	1.75	7.50	12.00	4.00	2.00	1.50	0.30
+0.30	+0.10	+0.10	+0.10	+0.10	+0.10	+0.10	+0.10	+0.10	+0.10	+0.05
-0.10	-0.10	-0.10	-0.10	-0.10	-0.10	-0.10	-0.10	-0.10	-0.00	-0.05

Korea Sales Office (KOREA) +82)31-904-1444  
 China Sales Office (CHINA) +86)0758-683-1444  
 Hungary Sales office (EUROPE) +36)1-404-5832

H.K Sales Office (HONGKONG) +852)2711-5551  
 LA Sales Office (USA) +1)714-616-6989

• You can also contact us by e-mail : [coilmaster@coilmaster.com](mailto:coilmaster@coilmaster.com)

- All specifications are subject to change without notice.
- Update date : 2024.07.25

[www.coilmaster.com](http://www.coilmaster.com)