

# CMI-CMMPF10100QL-SB SERIES

## Features

- ▶ Metal powder molding type for EMC protection.
- ▶ Lower DCR with applying flat wire.
- ▶ Available tape and reel for auto insertion.
- ▶ Halogen-Free.
- ▶ RoHS compliant.
- ▶ AEC-Q200 qualified.

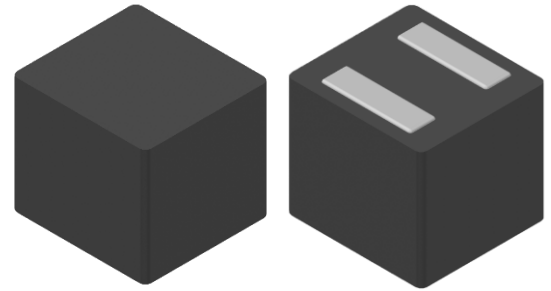

## Applications

- ▶ Equipment using for automobiles (ECM, Airbags, Headlights, Electronic Power steering, Motors, ABS, other)

## Dimension (Unit:mm)

## Land Pattern (Unit:mm)

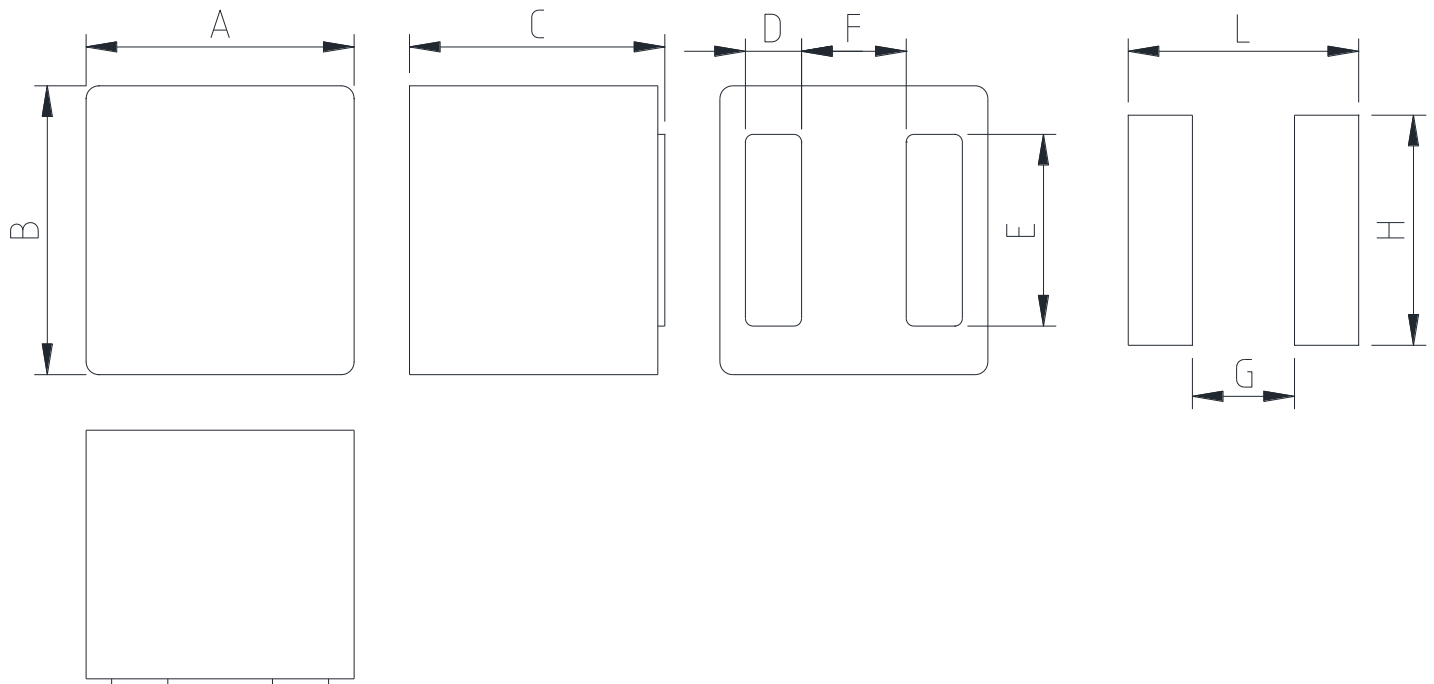

A	B	C	D	E	F	G	H	L
10.5 ±0.5	11.3 ±0.5	10.0 Max.	2.2 ±0.2	7.5 Typ.	4.1 Typ.	4.00	9.00	9.03

• You can also contact us by e-mail : [coilmaster@coilmaster.com](mailto:coilmaster@coilmaster.com)  
 • All specifications are subject to change without notice.  
 • Update date : 2024.09.27

## Regulation of part number

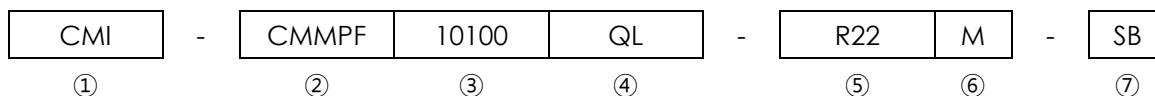

- ① CoilMaster's initial
- ② Series Name : Car Metal Molded Power inductor Flat wire type.
- ③ Core Size (unit:mm)
- ④ Material
- ⑤ Typical inductance value (0.22uH)
- ⑥ Inductance tolerance ( $\pm 20\%$ )
- ⑦ Type (SB)

## Specifications

Part Number	Inductance (uH) $\pm 20\%$	DCR(mohm) Max.(Typ.)	Isat(A) Max.(Typ.)	Itemp(A) Max.(Typ.)	Test Frequency (Hz)
CMI-CMMPF10100QL-R22M-SB	0.22	0.5(0.4)	89.0(99.0)	52.8(55.5)	1M
CMI-CMMPF10100QL-R47M-SB	0.47	0.72(0.6)	63.5(70.5)	50.4(53.0)	1M
CMI-CMMPF10100QL-R68M-SB	0.68	1.0(0.8)	56.0(62.0)	48.5(51.0)	1M
CMI-CMMPF10100QL-1R0M-SB	1.0	1.1(0.9)	46.0(55.0)	45.0(50.0)	1M
CMI-CMMPF10100QL-1R5M-SB	1.5	2.2(1.8)	37.0(42.0)	43.0(45.0)	1M
CMI-CMMPF10100QL-2R2M-SB	2.2	2.8(2.3)	30.5(34.0)	32.0(34.0)	1M
CMI-CMMPF10100QL-3R3M-SB	3.3	4.1(3.4)	24.3(27.0)	25.5(27.0)	1M
CMI-CMMPF10100QL-4R7M-SB	4.7	5.7(4.7)	21.5(23.5)	24.5(26.0)	1M
CMI-CMMPF10100QL-5R6M-SB	5.6	7.0(5.8)	20.0(22.5)	21.5(23.0)	1M
CMI-CMMPF10100QL-6R8M-SB	6.8	8.9(7.4)	19.0(21.0)	19.0(20.0)	1M
CMI-CMMPF10100QL-8R2M-SB	8.2	13(11)	16.0(18.3)	18.0(19.0)	1M
CMI-CMMPF10100QL-100M-SB	10	15(12.5)	15.8(17.5)	15.0(16.0)	1M
CMI-CMMPF10100QL-150M-SB	15	18.6(15.5)	11.0(13.0)	13.8(14.5)	1M

- Isat: When based on the inductance change rate (Approximately 30% below in the initial value)
- Itemp: When based on the temperature increase (Temperature increase of approximately 40°C by self heating)
- Operating Temperature Range (including self temperature) : -40°C ~ +165 °c

Note 1 : Circuit design, component placement, PCB trace size and thickness, airflow and other cooling. Provision all affect the part Temperature. Part temperature should be verified in the end application.

▪ You can also contact us by e-mail : [coilmaster@coilmaster.com](mailto:coilmaster@coilmaster.com)

- All specifications are subject to change without notice.
- Update date : 2024.09.27

[www.coilmaster.com](http://www.coilmaster.com)

# Electrical characteristics

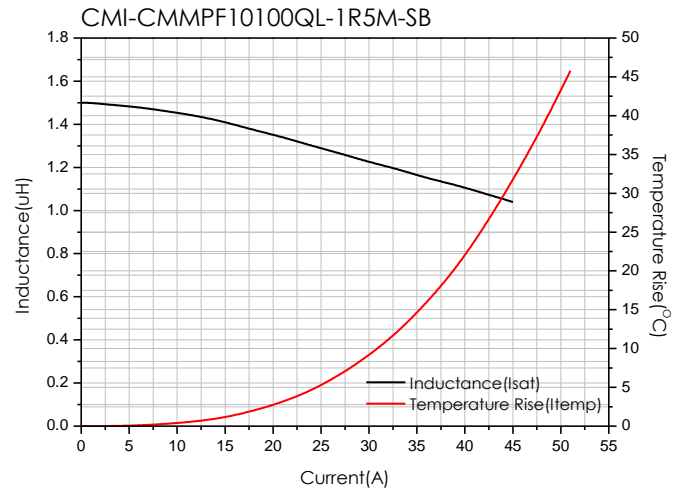
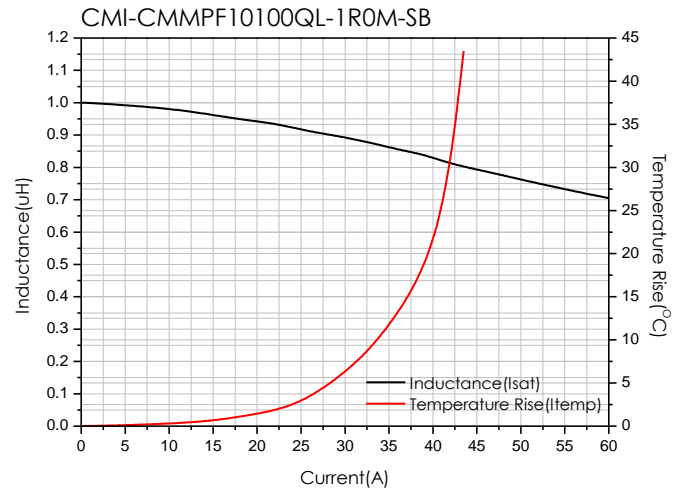
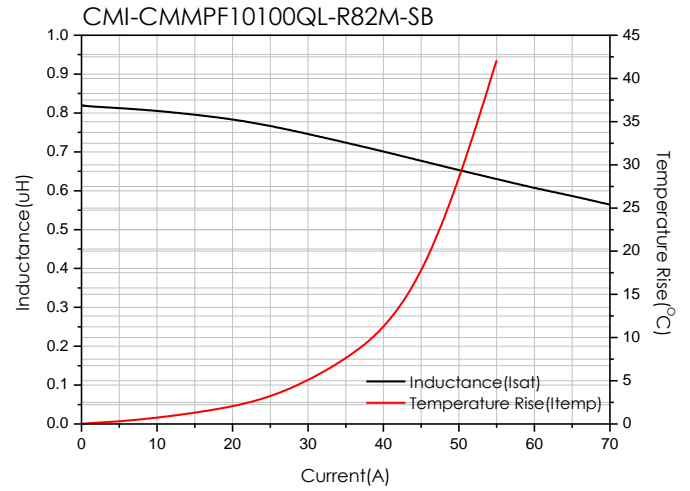
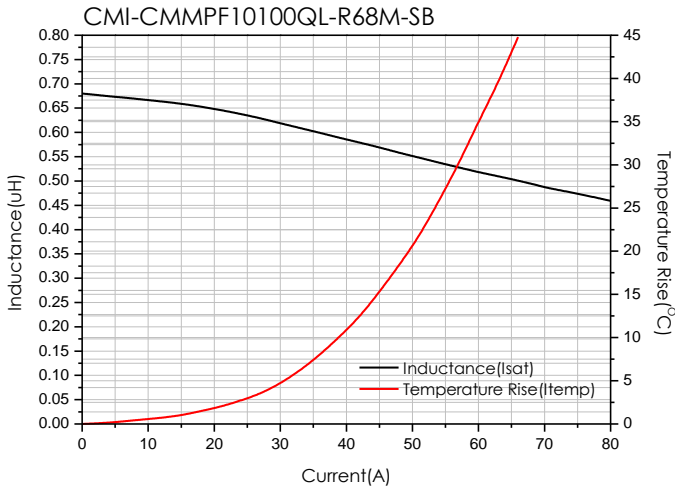
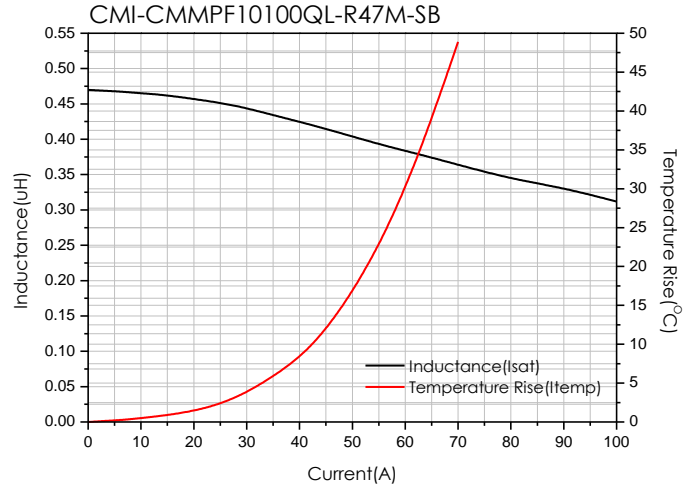
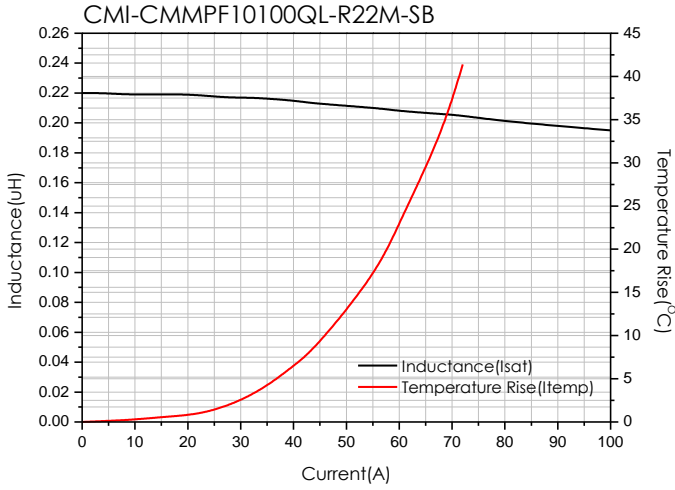

- You can also contact us by e-mail : [coilmaster@coilmaster.com](mailto:coilmaster@coilmaster.com)
- All specifications are subject to change without notice.
- Update date : 2024.09.27

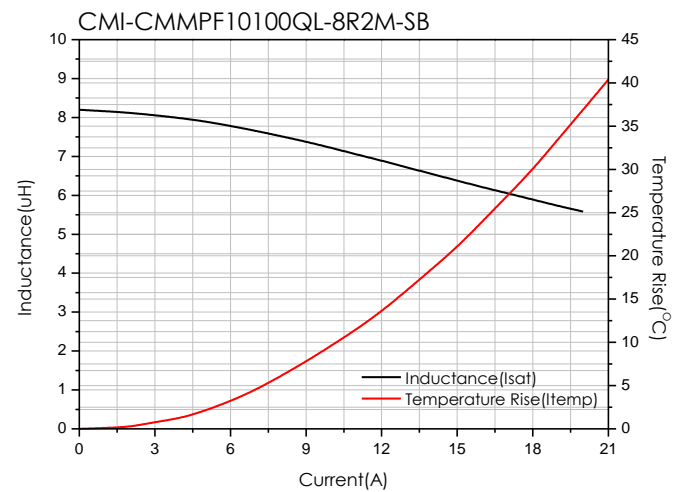
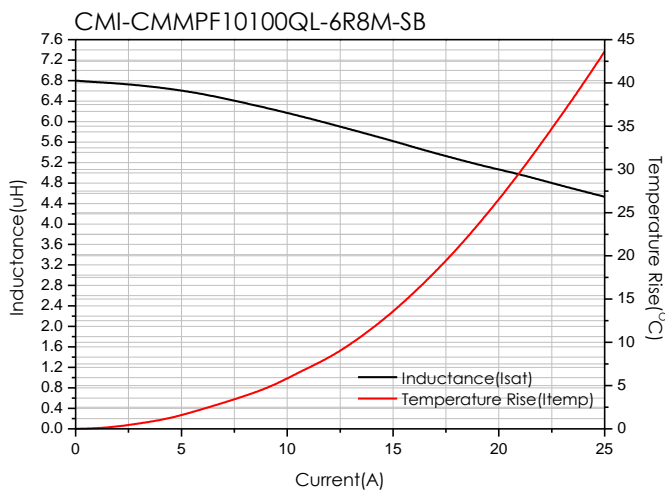
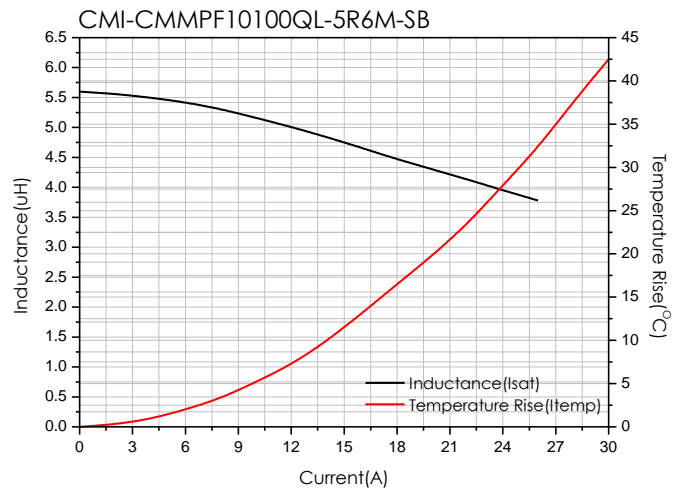
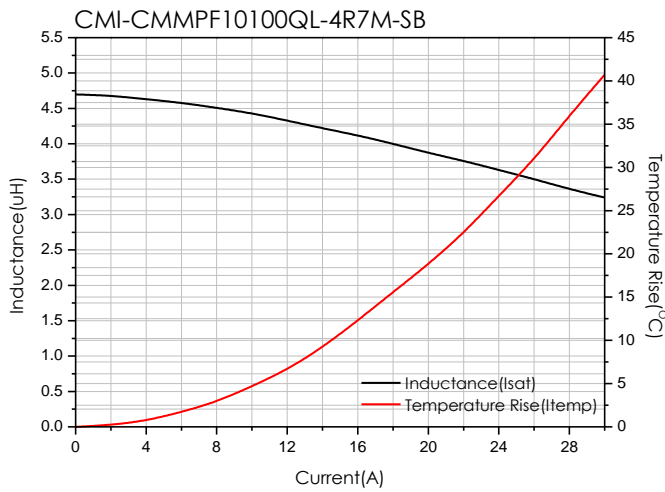
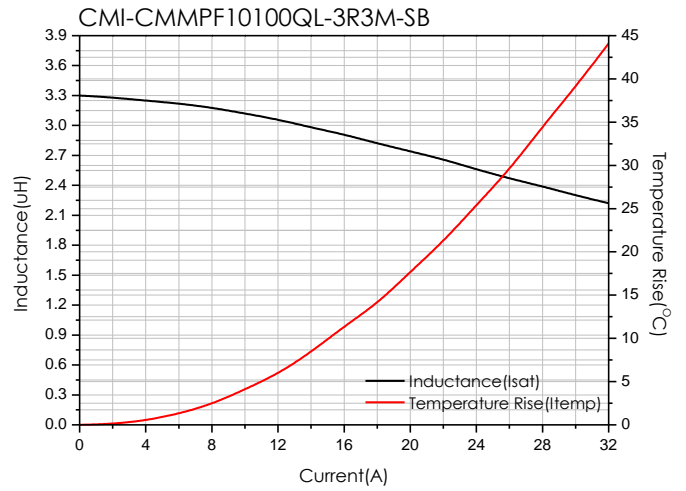
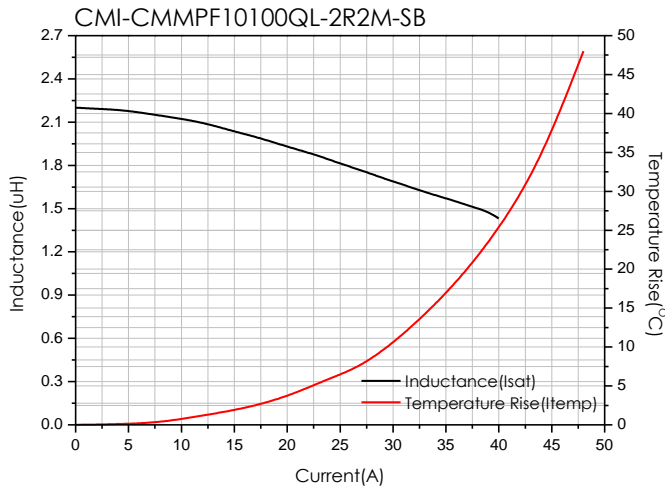

- You can also contact us by e-mail : [coilmaster@coilmaster.com](mailto:coilmaster@coilmaster.com)
- All specifications are subject to change without notice.
- Update date : 2024.09.27

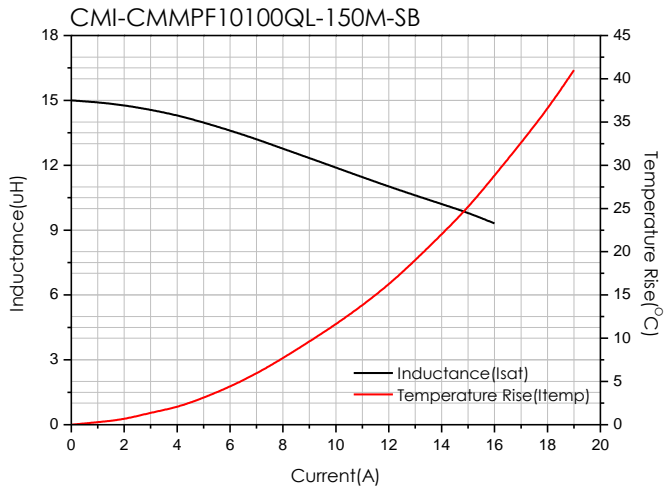

- You can also contact us by e-mail : [coilmaster@coilmaster.com](mailto:coilmaster@coilmaster.com)
- All specifications are subject to change without notice.
- Update date : 2024.09.27

## Packaging

(1) Package quantity : 250 (pcs/reel)

(2) Reel Dimensions (unit:mm)

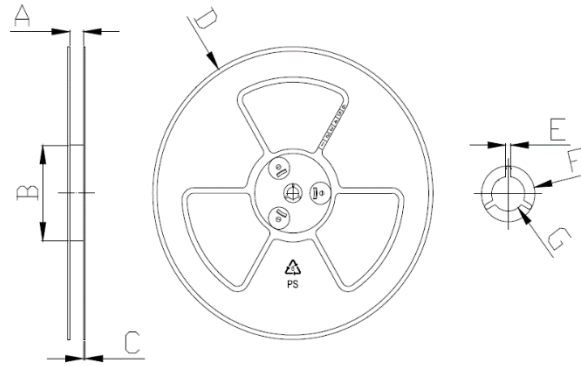

A	B	C	D	E	F	G
24.50	100.0	2.00	330.0	2.30	21.50	13.00
+0.50	+1.00	+0.20	+3.00	+0.30	+0.30	+0.50
-0.50	-1.00	-0.20	-3.00	-0.30	-0.30	-0.20

(3) Tape Dimensions

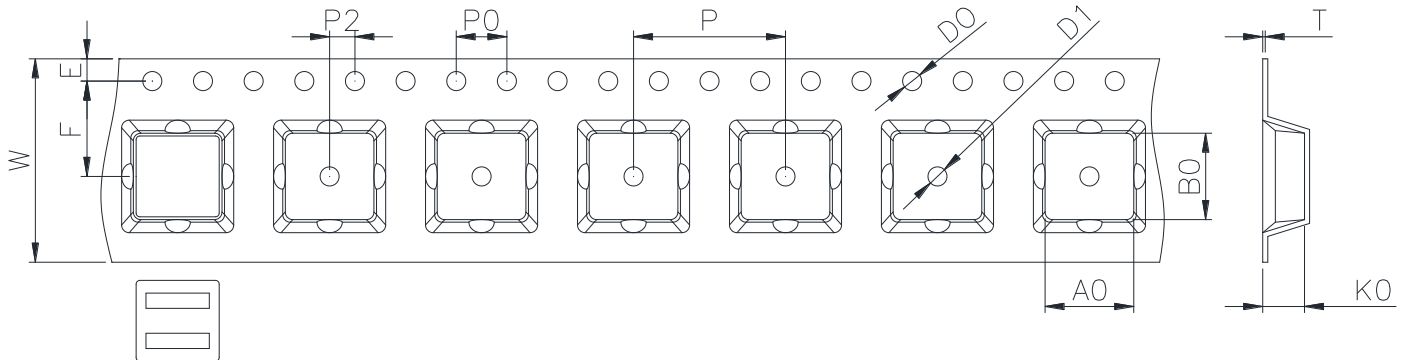

W	A0	B0	K0	E	F	P	P0	P2	D0/D1	T
24.00	12.00	10.80	10.20	1.75	11.50	20.00	4.00	2.00	1.50	0.50
+0.30	+0.10	+0.10	+0.10	+0.10	+0.10	+0.10	+0.10	+0.10	+0.10	+0.05
-0.10	-0.10	-0.10	-0.10	-0.10	-0.10	-0.10	-0.10	-0.10	-0.00	-0.05

Korea Sales Office (KOREA) +82)31-904-1444  
 China Sales Office (CHINA) +86)0758-683-1444  
 Hungary Sales office (EUROPE) +36)1-404-5832

H.K Sales Office (HONGKONG) +852)2711-5551  
 LA Sales Office (USA) +1)714-616-6989

• You can also contact us by e-mail : [coilmaster@coilmaster.com](mailto:coilmaster@coilmaster.com)

- All specifications are subject to change without notice.
- Update date : 2024.09.27

[www.coilmaster.com](http://www.coilmaster.com)