

# CMI-CMMPF201208BC-NC SERIES

## Features

- ▶ Low Power Loss Metal molding type Inductor.
- ▶ Small size and Low profile.
- ▶ Lower DCR with applying flat wire.
- ▶ Compact design.
- ▶ EMC protection.
- ▶ Available tape and reel for auto insertion.
- ▶ RoHS & Halogen-Free compliant.
- ▶ AEC-Q200 qualified.

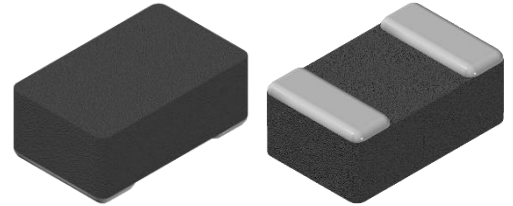

## Applications

- ▶ For Negative DC/DC converter (Mobile phone, Tablet, W/QHD Display)
- ▶ Mobility application that devices requiring high efficiency in low power mode.

## Dimension (Unit:mm)

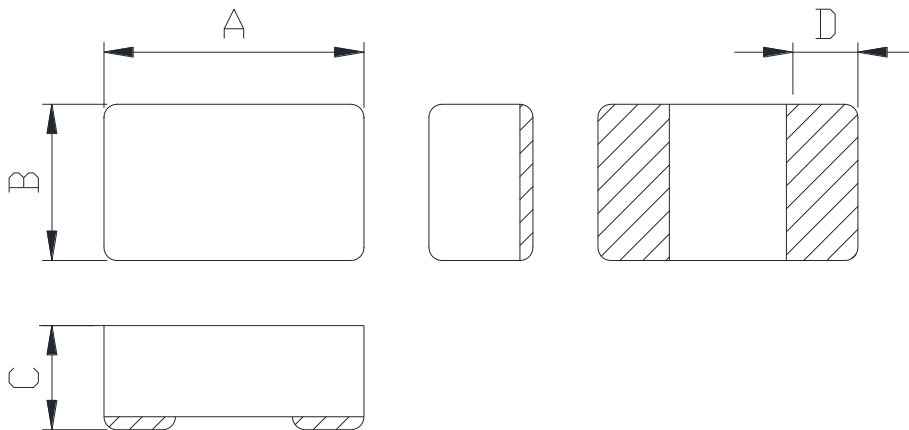

A	B	C	D
2.0 ±0.2	1.2 ±0.2	0.8 Max.	0.5 ±0.3

## Land Pattern (Unit:mm)

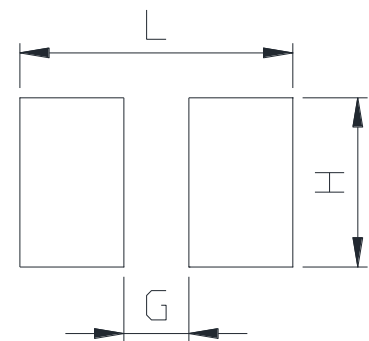

L	G	H
2.4	0.8	1.4

## Regulation of part number

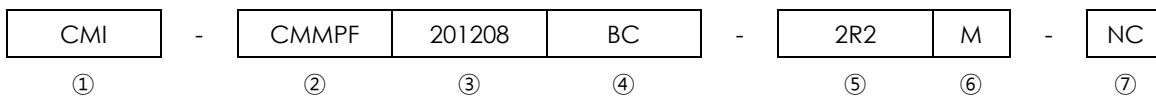

- ① CoilMaster's initial
- ② Series Name : Car Metal Molded Flat wire Power inductor
- ③ Core Size (unit:mm)
- ④ Type
- ⑤ Typical inductance value (2.2uH)
- ⑥ Inductance tolerance (±20%)
- ⑦ Internal code (NC)

## Specifications

Part Number	Inductance (uH) ±20%	DCR(mohm) Max.(Typ.)	Isat(A) Max.(Typ.)	Itemp(A) Max.(Typ.)	Test Frequency (Hz)
CMI-CMMPF201208BC-2R2M-NC	2.2	260(225)	2.3(2.5)	1.4(1.6)	1M

- Isat: When based on the inductance change rate (Approximately 30% below in the initial value)
- Itemp: When based on the temperature increase (Temperature increase of approximately 40°c by self heating)
- Operating Temperature Range (including self temperature) : -40°c ~ +150 °c

Note 1 : Circuit design, component placement, PCB trace size and thickness, airflow and other cooling. Provision all affect the part Temperature. Part temperature should be verified in the end application.

- **You can also contact us by e-mail : coilmaster@coilmaster.com**
- All specifications are subject to change without notice.
- Update date : 2025.01.09

## Electrical characteristics

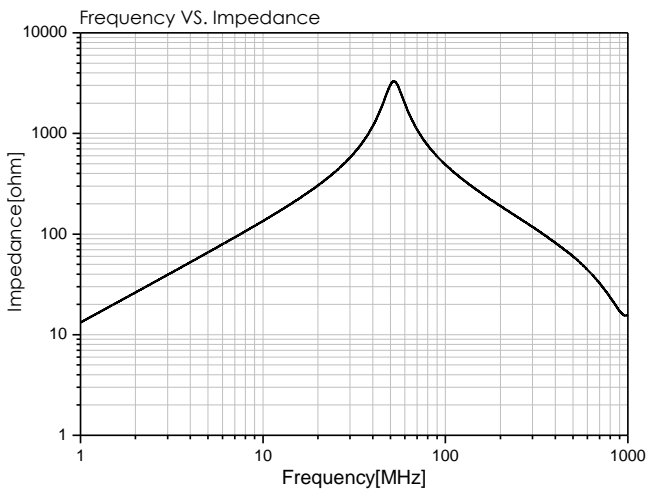
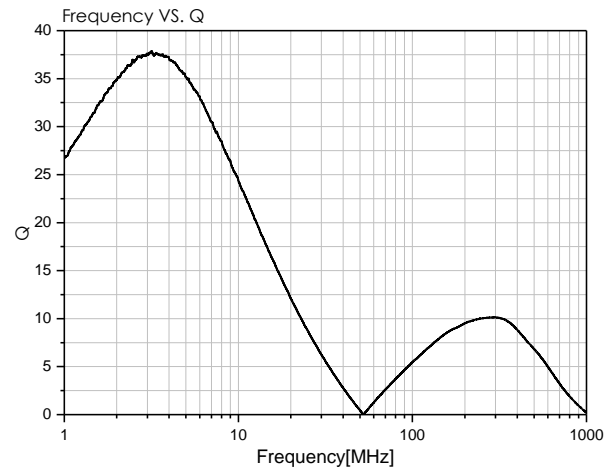
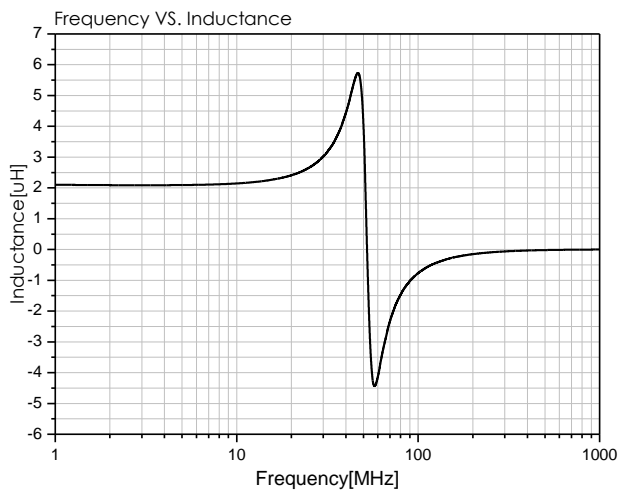
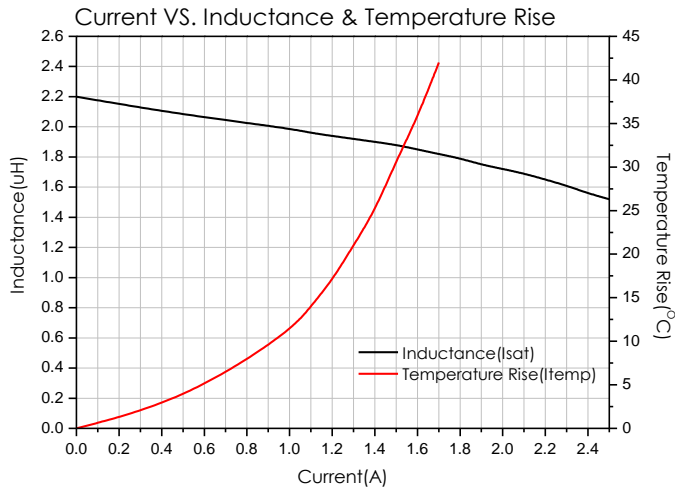

- You can also contact us by e-mail : [coilmaster@coilmaster.com](mailto:coilmaster@coilmaster.com)
- All specifications are subject to change without notice.
- Update date : 2025.01.09

## Packaging

(1) Package quantity : 3,000 (pcs/reel)

(2) Reel Dimensions (unit:mm)

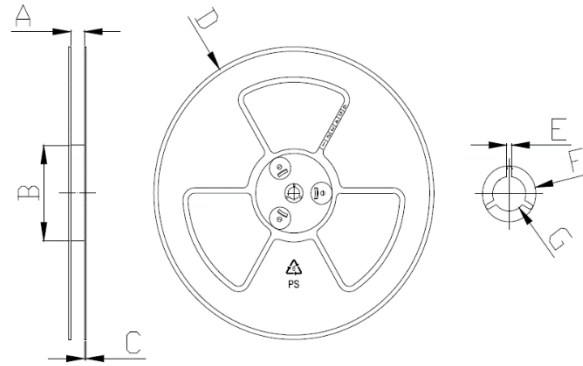

A	B	C	D	E	F	G
8.50	60.0	1.50	178.0	2.70	22.50	13.50
+0.50	+2.00	+0.20	+1.00	+0.30	+0.50	+0.50
-0.50	-2.00	-0.20	-1.00	-0.30	-0.50	-0.50

(3) Tape Dimensions

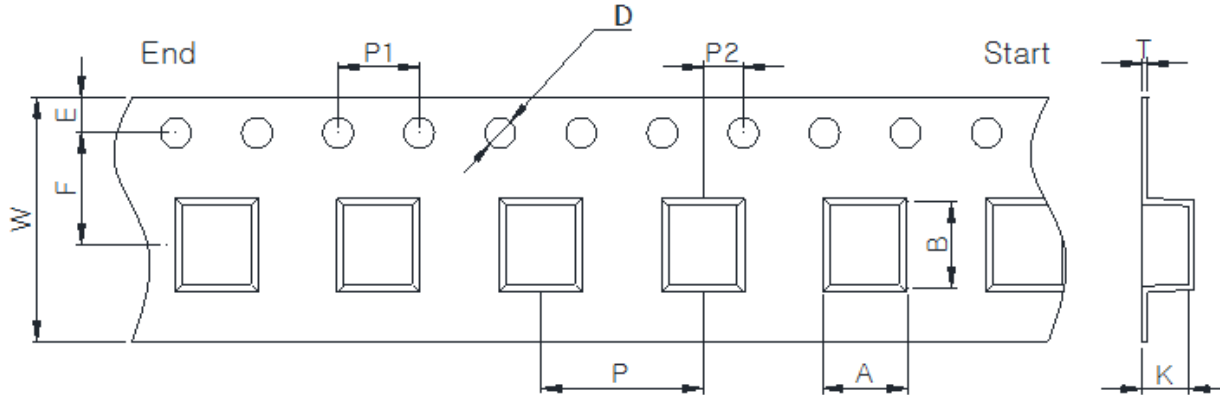

W	A	B	K	E	F	P	P1	P2	D	T
8.00	1.50	2.24	0.95	1.75	3.50	4.00	4.00	2.00	1.50	0.22
+0.10	+0.10	+0.10	+0.10	+0.15	+0.10	+0.10	+0.10	+0.05	+0.10	+0.05
-0.10	-0.10	-0.10	-0.10	-0.10	-0.10	-0.10	-0.10	-0.05	-0.00	-0.05

Korea Sales Office (KOREA) +82)31-904-1444  
 China Sales Office (CHINA) +86)0758-683-1444  
 Hungary Sales office (EUROPE) +36)1-404-5832

H.K Sales Office (HONGKONG) +852)2711-5551  
 LA Sales Office (USA) +1)714-616-6989

• You can also contact us by e-mail : [coilmaster@coilmaster.com](mailto:coilmaster@coilmaster.com)

- All specifications are subject to change without notice.
- Update date : 2025.01.09

[www.coilmaster.com](http://www.coilmaster.com)