

CMI-CMMPP17070HL-SERIES

Features

- ▶ Metal powder molding type for EMC protection.
- ▶ Available tape and reel for auto insertion.
- ▶ Halogen-Free.
- ▶ RoHS compliant.
- ▶ AEC-Q200 qualified.

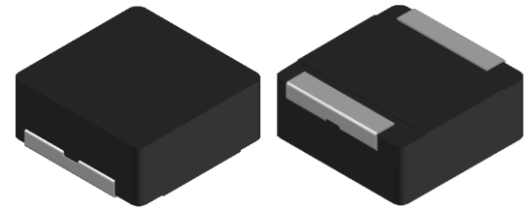

Applications

- ▶ Equipment using for automobiles (ECM, Airbags, Headlights, Electronic Power steering, Motors, ABS, other)

Dimension (Unit:mm)

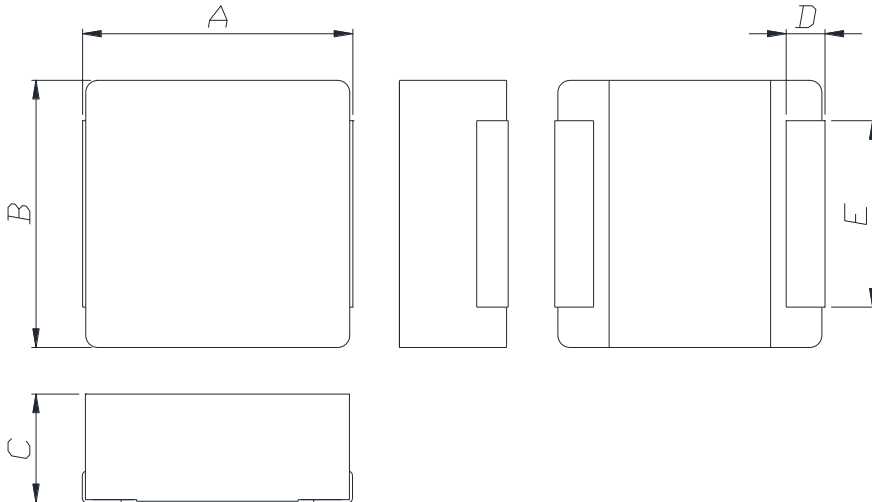

A	B	C	D	E
17.2 ±0.5	17.2 ±0.4	7.0 Max.	2.7 ±0.3	12.0 ±0.2

Land Pattern (Unit:mm)

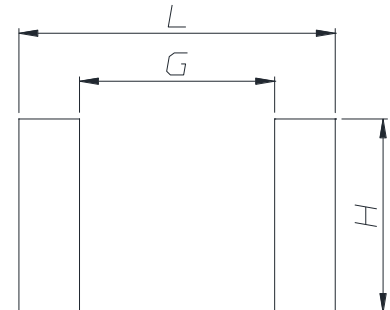

L	G	H
20.1	12.4	12.3

Regulation of part number

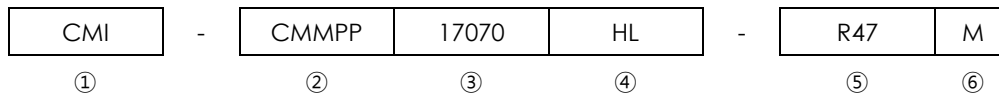

- ① CoilMaster's initial
- ② Series Name : Car Metal Molded Pin type Power inductor
- ③ Core Size (unit:mm)
- ④ Material
- ⑤ Typical inductance value (0.47uH)
- ⑥ Inductance tolerance (±20%)

Specifications

Part Number	Inductance (uH) ±20%	DCR(mohm) Max.(Typ.)	Isat(A) Max.(Typ.)	Itemp(A) Max.(Typ.)	Test Frequency (Hz)
CMI-CMMPP17070HL-R47M	0.47	0.9(0.6)	70.0(85.0)	50.0(55.0)	1M
CMI-CMMPP17070HL-1R0M	1.0	1.1(0.9)	55.0(70.0)	45.0(50.0)	1M
CMI-CMMPP17070HL-1R5M	1.5	2.7(2.2)	50.0(60.0)	40.0(42.0)	1M
CMI-CMMPP17070HL-2R2M	2.2	3.6(3)	45.0(50.0)	33.0(35.0)	1M
CMI-CMMPP17070HL-3R3M	3.3	5.4(4.5)	37.0(42.0)	32.0(34.0)	1M
CMI-CMMPP17070HL-4R7M	4.7	7.2(6)	30.0(35.0)	30.0(32.0)	1M
CMI-CMMPP17070HL-6R8M	6.8	11.4(9.5)	24.0(29.0)	21.0(22.0)	1M
CMI-CMMPP17070HL-8R2M	8.2	13.2(11)	20.0(23.0)	19.0(20.0)	1M
CMI-CMMPP17070HL-100M	10	15(12.5)	18.0(21.0)	18.5(19.0)	1M
CMI-CMMPP17070HL-150M	15	24(20)	17.0(19.0)	14.0(14.5)	1M
CMI-CMMPP17070HL-220M	22	30(25)	12.0(14.0)	12.5(13.0)	1M
CMI-CMMPP17070HL-330M	33	48(40)	11.0(12.0)	11.0(12.0)	1M
CMI-CMMPP17070HL-101M	100.0	168(140)	6.5(7.5)	6.0(6.5)	1M

- Isat: When based on the inductance change rate (Approximately 30% below in the initial value)
- Itemp: When based on the temperature increase (Temperature increase of approximately 40°C by self heating)
- Operating Temperature Range (including self temperature) : -40°C ~ +165 °c

Note 1 : Circuit design, component placement, PCB trace size and thickness, airflow and other cooling. Provision all affect the part Temperature. Part temperature should be verified in the end application.

▪ **You can also contact us by e-mail : coilmaster@coilmaster.com**

- All specifications are subject to change without notice.
- Update date : 2023.03.30

www.coilmaster.com

Electrical characteristics

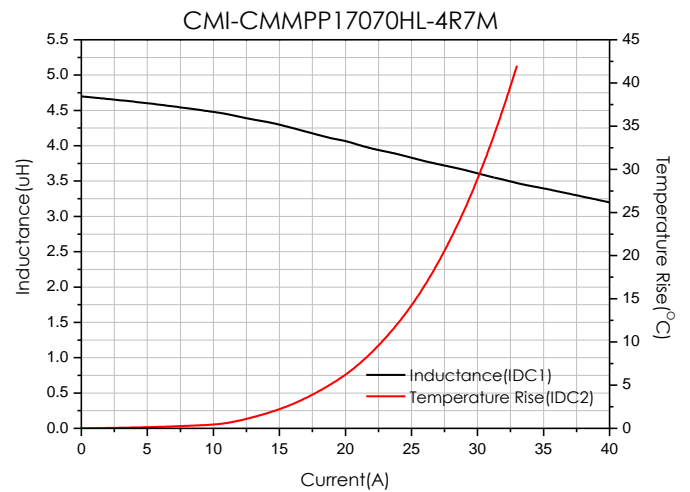
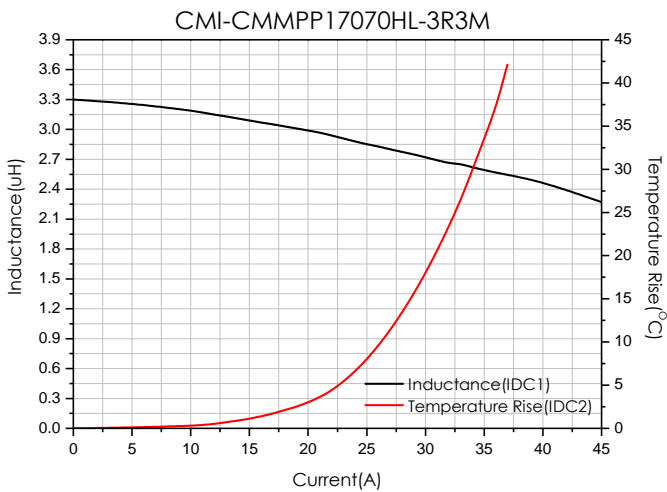
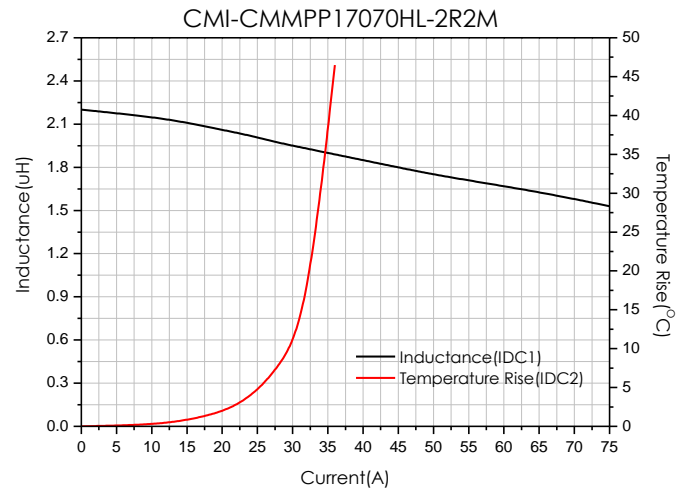
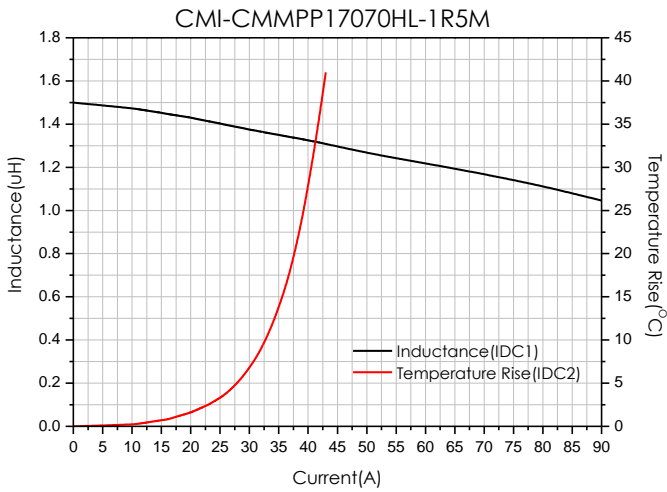
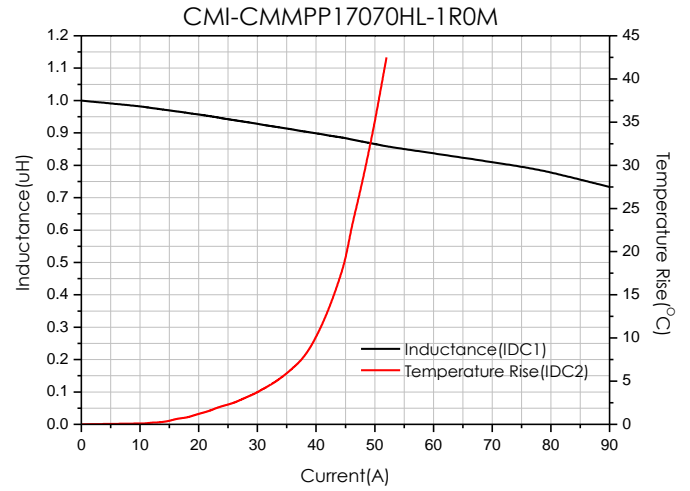
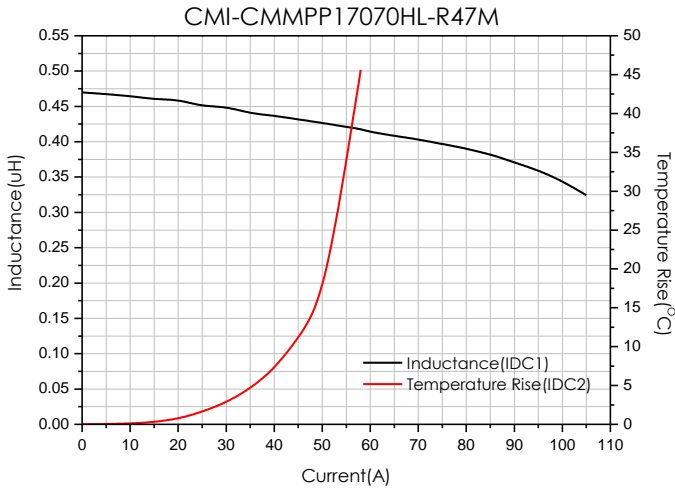

- You can also contact us by e-mail : coilmaster@coilmaster.com
- All specifications are subject to change without notice.
- Update date : 2023.03.30

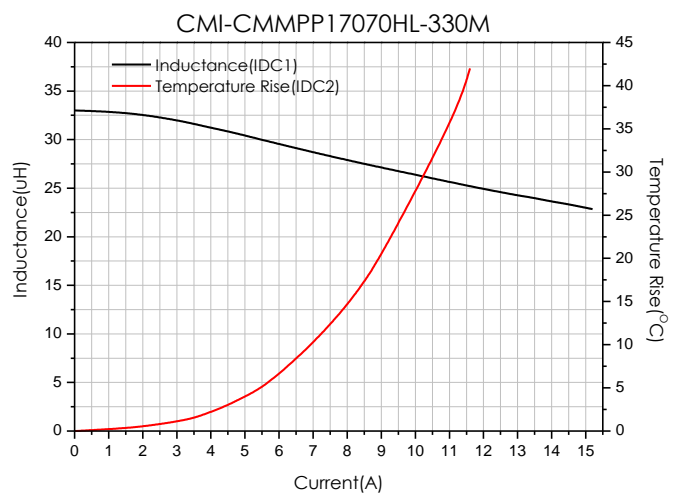
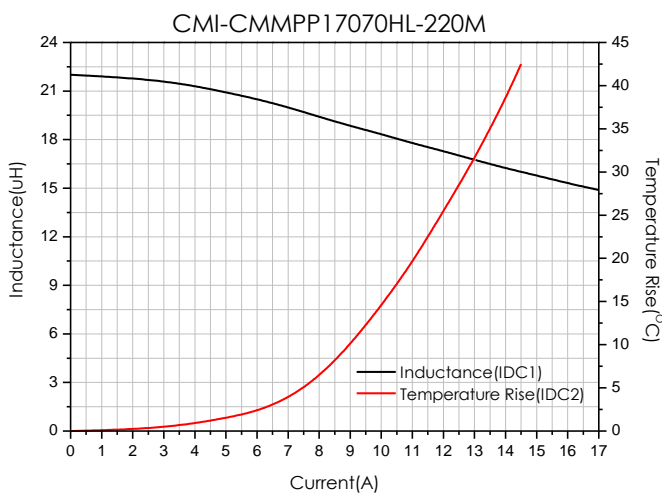
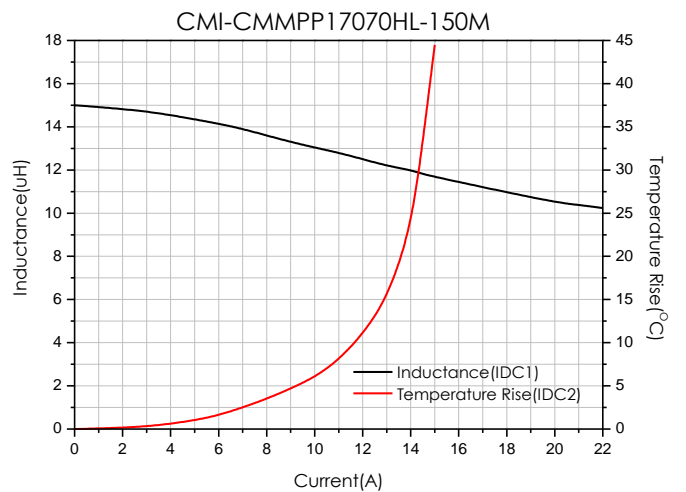
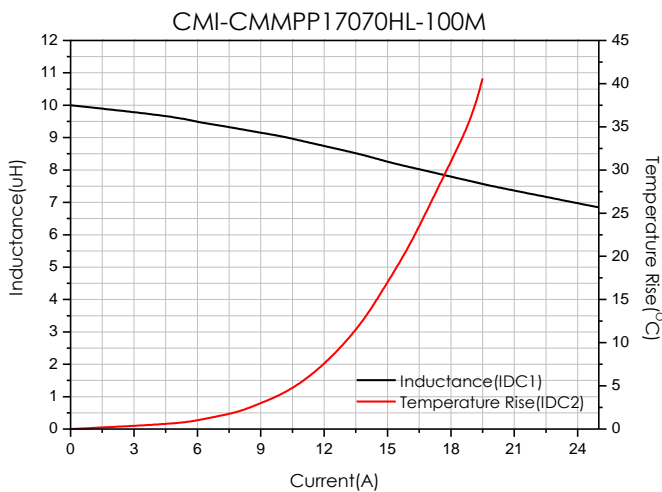
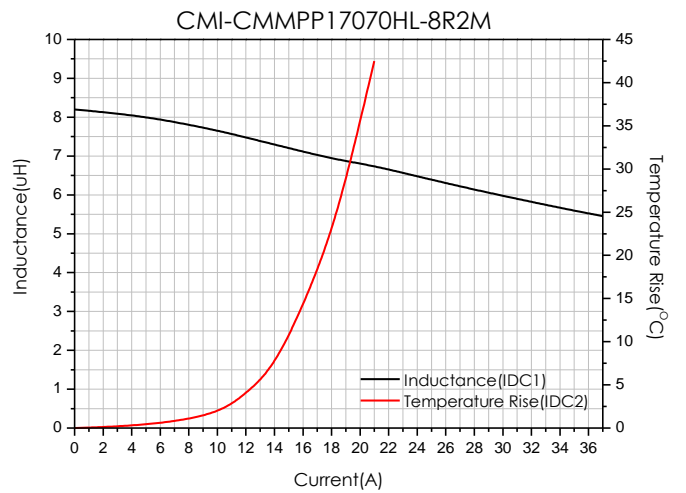
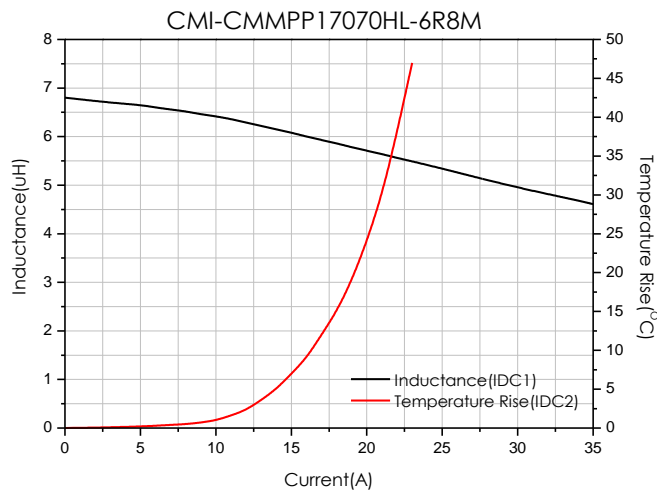

• You can also contact us by e-mail : coilmaster@coilmaster.com
 • All specifications are subject to change without notice.
 • Update date : 2023.03.30

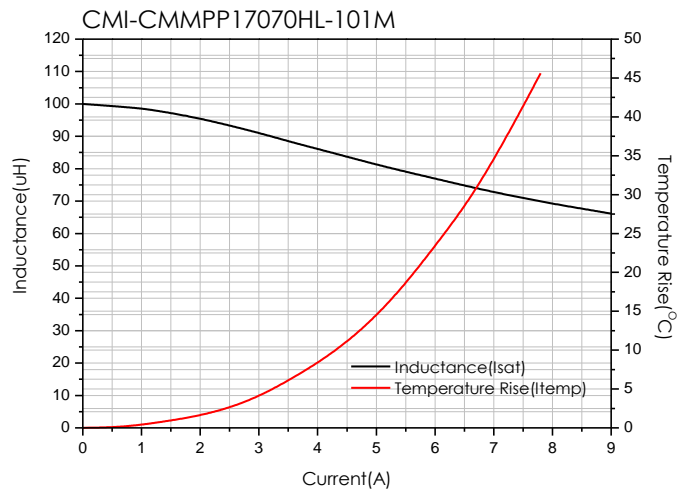

- You can also contact us by e-mail : coilmaster@coilmaster.com
- All specifications are subject to change without notice.
- Update date : 2023.03.30

Packaging

(1) Package quantity : 300 (pcs/reel)

(2) Reel Dimensions (unit:mm)

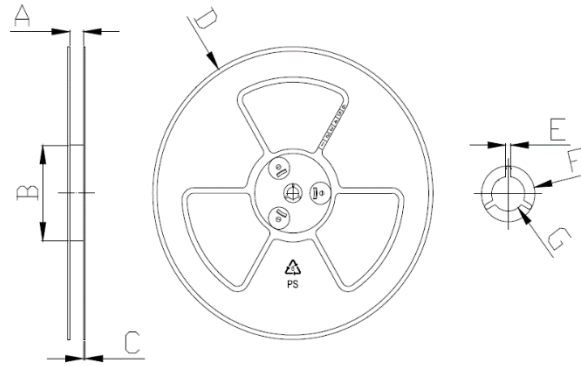

A	B	C	D	E	F	G
32.50	100.0	2.30	330.0	2.30	21.50	13.00
+0.50	+1.00	+0.20	+3.00	+0.30	+0.30	+0.50
-0.50	-1.00	-0.20	-3.00	-0.30	-0.30	-0.20

(3) Tape Dimensions

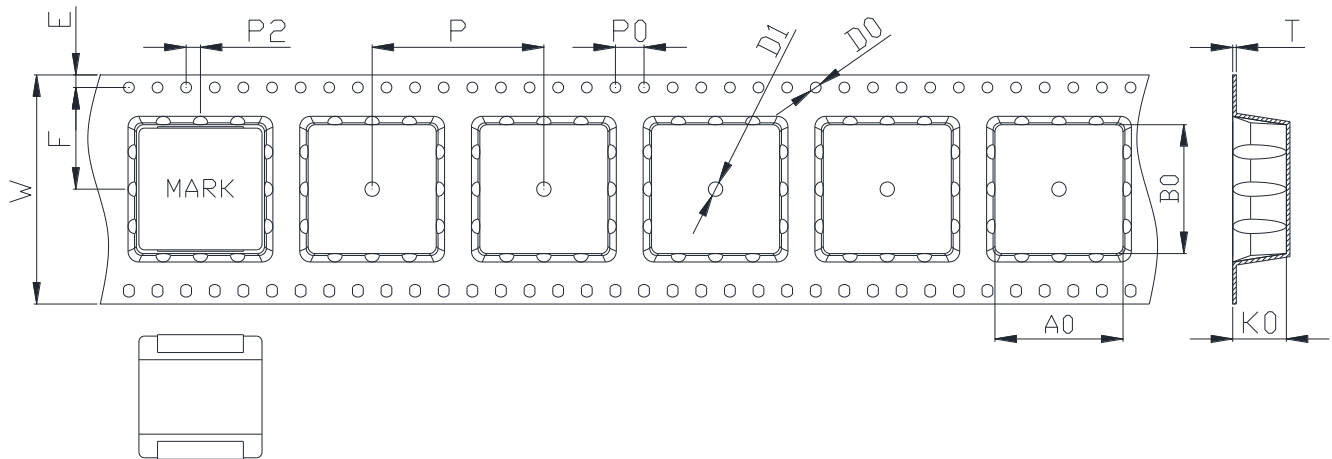

W	A0	B0	K0	E	F	P	P0	P2	D0	T
32.00	17.90	18.00	7.50	1.75	14.20	24.00	4.00	2.00	1.55	0.50
+0.30	+0.10	+0.10	+0.10	+0.10	+0.10	+0.10	+0.10	+0.10	+0.05	+0.05
-0.30	-0.10	-0.10	-0.10	-0.10	-0.10	-0.10	-0.10	-0.10	-0.05	-0.05

Korea Sales Office (KOREA) +82)31-904-1444
 China Sales Office (CHINA) +86)0758-683-1444
 Hungary Sales office (EUROPE) +36)1-404-5832

H.K Sales Office (HONGKONG) +852)2711-5551
 LA Sales Office (USA) +1)714-616-6989

• You can also contact us by e-mail : coilmaster@coilmaster.com

- All specifications are subject to change without notice.
- Update date : 2023.03.30

www.coilmaster.com