

CMI-CMMPP252012MH-SERIES

Features

- ▶ Small size and low profile.
- ▶ Metal powder molding type for EMC protection.
- ▶ Available tape and reel for auto insertion.
- ▶ Halogen-Free.
- ▶ RoHS compliant.
- ▶ AEC-Q200 qualified.

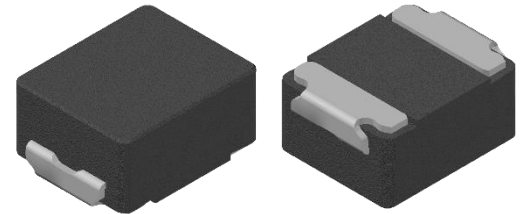

Applications

- ▶ Equipment using for automobiles
(ECM, airbags, headlights, electronic Power steering, motors, ABS, other)

Dimension (Unit:mm)

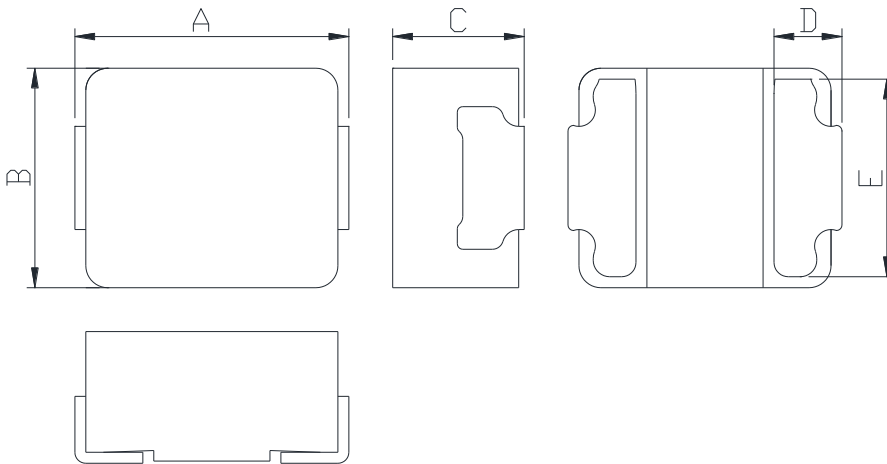

| A | B | C | D | E |
|----------|----------|----------|-----------|----------|
| 2.5 ±0.2 | 2.0 ±0.2 | 1.2 Max. | 0.65 ±0.1 | 1.8 ±0.3 |

Land Pattern (Unit:mm)

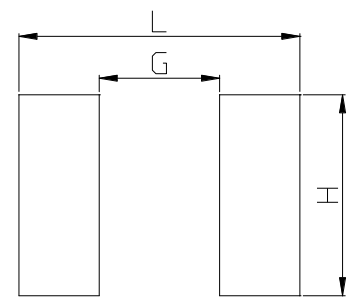

| L | G | H |
|------|------|------|
| 2.80 | 1.20 | 2.00 |

Regulation of part number

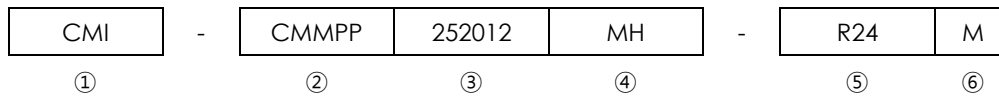

- ① CoilMaster's initial
- ② Series Name : Car Metal Molded Pin type Power inductor
- ③ Series Size (unit:mm)
- ④ Material
- ⑤ Typical inductance value (0.24uH)
- ⑥ Inductance tolerance ($\pm 20\%$)

Specifications

| Part Number | Inductance (uH) $\pm 20\%$ | DCR(mohm) Max.(Typ.) | Isat(A) Max.(Typ.) | Itemp(A) Max.(Typ.) | Test Frequency (Hz) |
|------------------------|-------------------------------|-------------------------|-----------------------|------------------------|---------------------------|
| CMI-CMMPP252012MH-R24M | 0.24 | 20.4(17) | 8.90(9.90) | 5.10(5.70) | 1M |
| CMI-CMMPP252012MH-R33M | 0.33 | 21.6(18) | 6.60(7.40) | 5.00(5.60) | 1M |
| CMI-CMMPP252012MH-R47M | 0.47 | 26.4(22) | 5.60(6.20) | 4.60(5.10) | 1M |
| CMI-CMMPP252012MH-R68M | 0.68 | 36(30) | 4.30(4.80) | 3.90(4.30) | 1M |
| CMI-CMMPP252012MH-1R0M | 1.0 | 51.6(43) | 3.90(4.40) | 3.20(3.60) | 1M |
| CMI-CMMPP252012MH-1R5M | 1.5 | 73.2(61) | 3.40(3.80) | 2.60(2.90) | 1M |
| CMI-CMMPP252012MH-2R2M | 2.2 | 112(94) | 2.80(3.10) | 2.10(2.30) | 1M |
| CMI-CMMPP252012MH-3R3M | 3.3 | 147(123) | 2.30(2.60) | 1.90(2.10) | 1M |
| CMI-CMMPP252012MH-4R7M | 4.7 | 224(187) | 1.70(1.90) | 1.40(1.60) | 1M |
| CMI-CMMPP252012MH-6R8M | 6.8 | 312(260) | 1.60(1.80) | 1.25(1.40) | 1M |
| CMI-CMMPP252012MH-R24M | 0.24 | 20.4(17) | 8.90(9.90) | 5.10(5.70) | 1M |
| | | | | | |
| | | | | | |
| | | | | | |
| | | | | | |
| | | | | | |

- Isat: When based on the inductance change rate (Approximately 30% below in the initial value)
- Itemp: When based on the temperature increase (Temperature increase of approximately 40°C by self heating)
- Operating Temperature Range (including self temperature) : -40°C ~ +165 °c

Note 1 : Circuit design, component placement, PCB trace size and thickness, airflow and other cooling. Provision all affect the part Temperature. Part temperature should be verified in the end application.

▪ **You can also contact us by e-mail : coilmaster@coilmaster.com**

- All specifications are subject to change without notice.
- Update date : 2023.08.10

www.coilmaster.com

Specifications

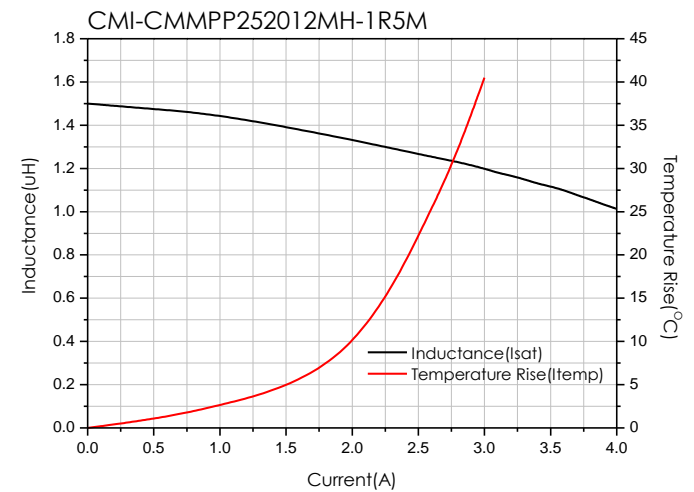
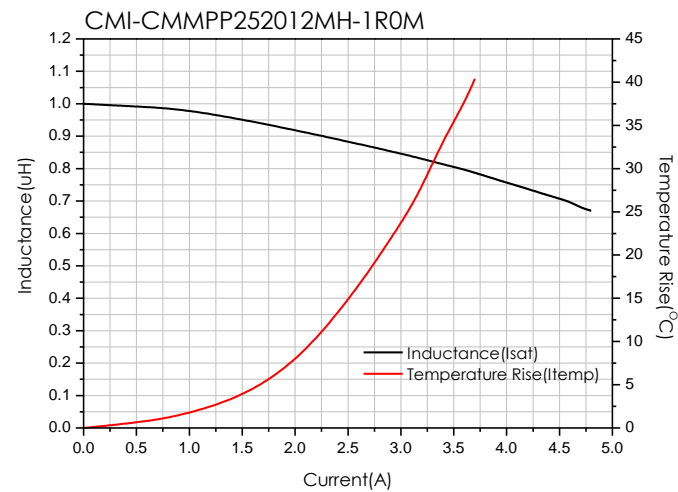
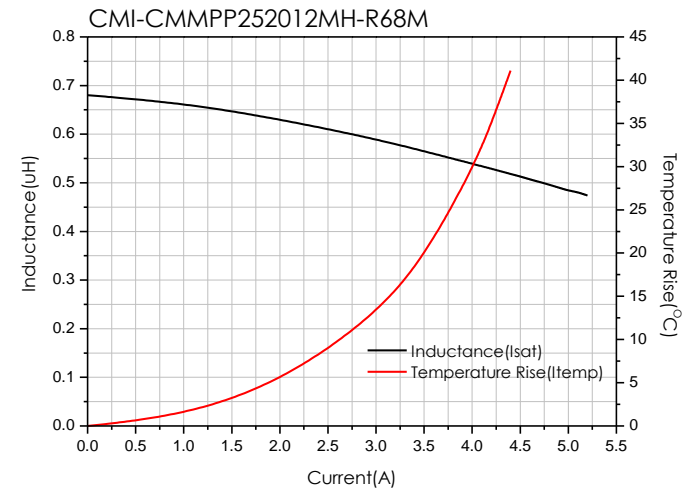
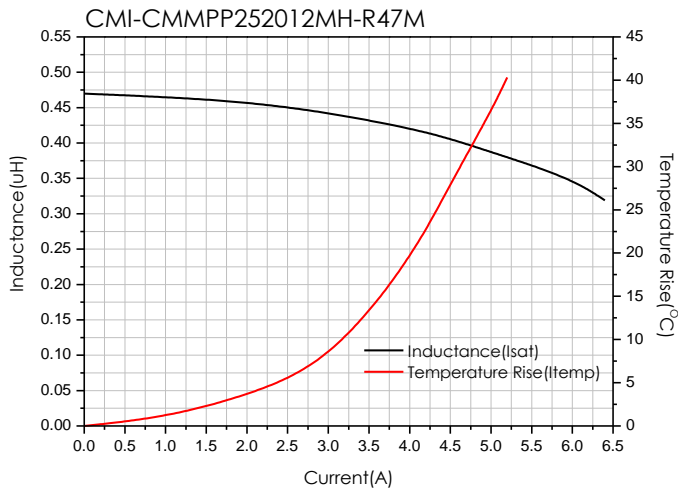
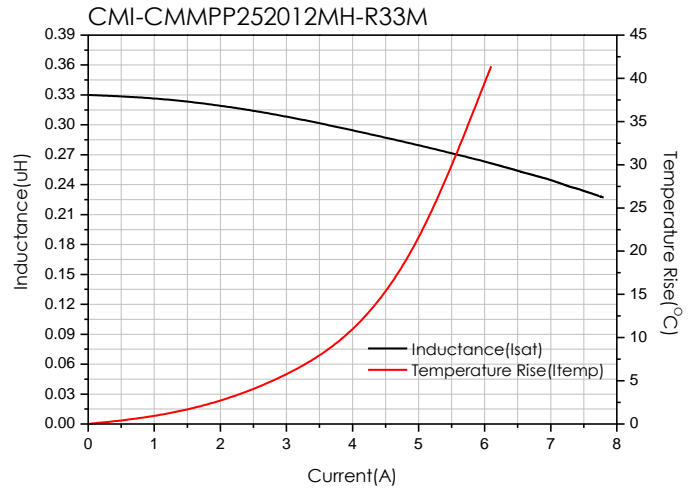
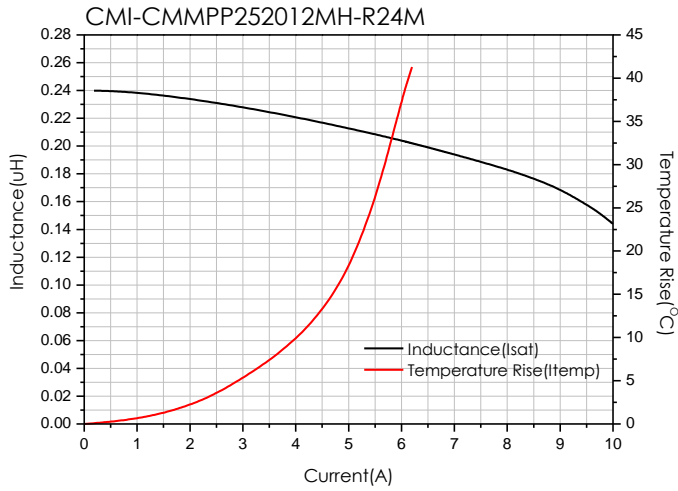

- You can also contact us by e-mail : coilmaster@coilmaster.com
- All specifications are subject to change without notice.
- Update date : 2023.08.10

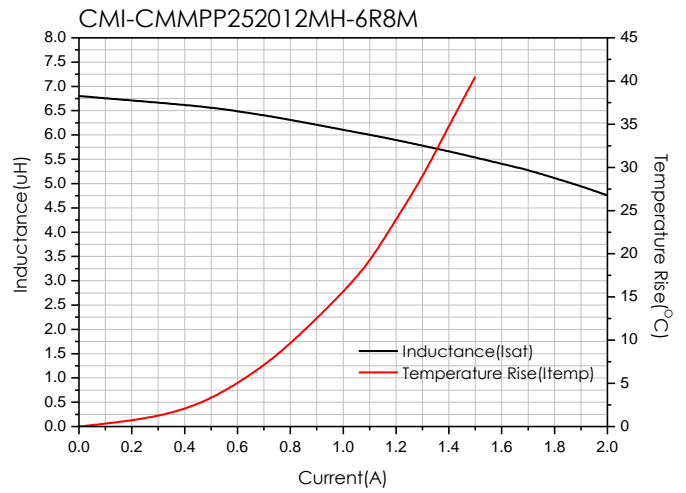
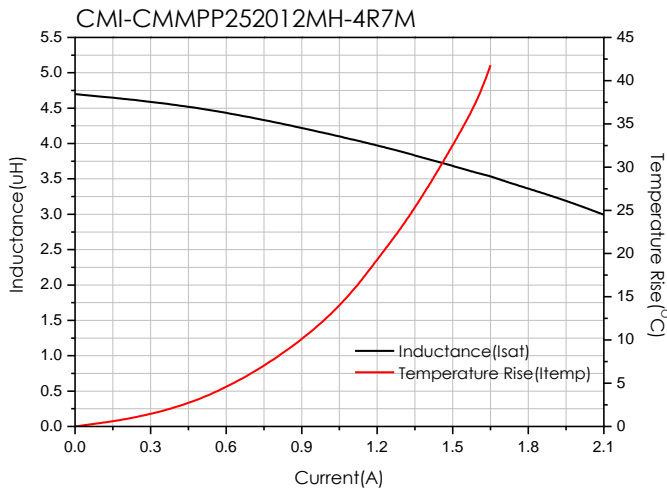
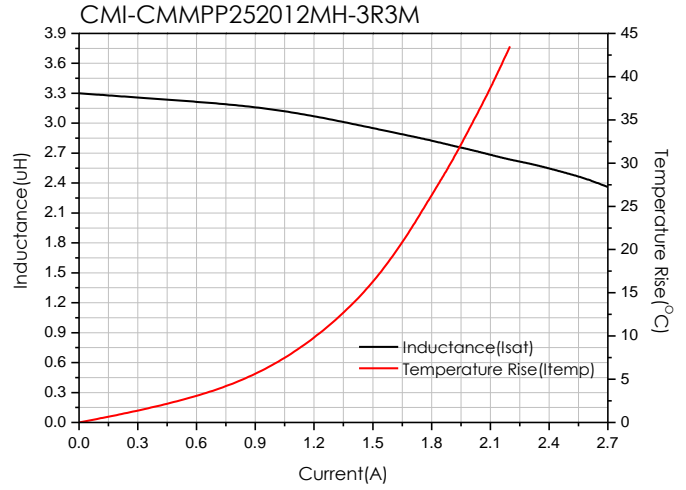
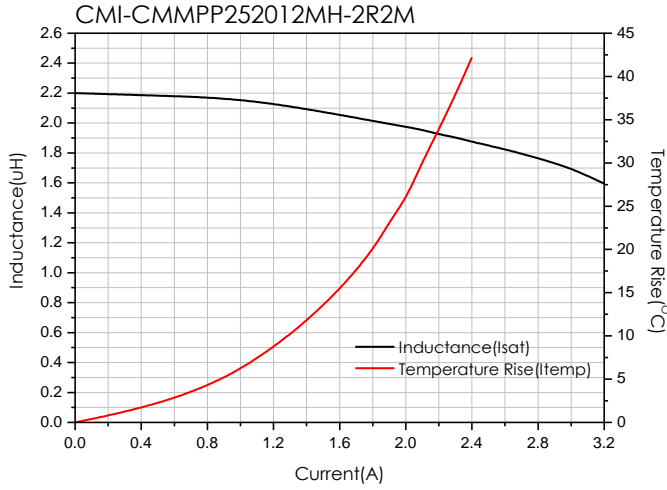

- You can also contact us by e-mail : coilmaster@coilmaster.com
- All specifications are subject to change without notice.
- Update date : 2023.08.10

Packaging

(1) Package quantity : 3,000 (pcs/reel)

(2) Reel Dimensions (unit:mm)

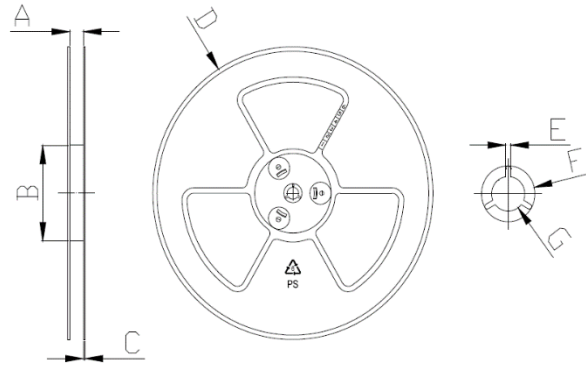

| A | B | C | D | E | F | G |
|-------|-------|-------|-------|-------|-------|-------|
| 8.50 | 60.0 | 1.50 | 178.0 | 2.70 | 22.50 | 13.50 |
| +0.50 | +2.00 | +0.20 | +1.00 | +0.30 | +0.50 | +0.50 |
| -0.50 | -2.00 | -0.20 | -1.00 | -0.30 | -0.50 | -0.50 |

(3) Tape Dimensions

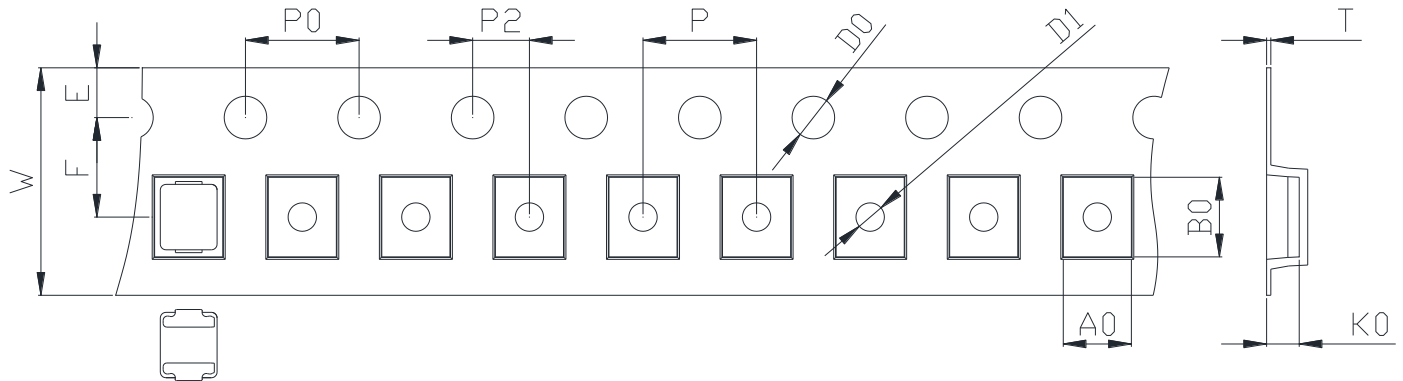

| W | A0 | B0 | K0 | E | F | P/P0 | P2 | D0 | D1 | T |
|-------|-------|-------|-------|-------|-------|-------|-------|-------|-------|-------|
| 8.00 | 2.45 | 3.05 | 1.30 | 1.75 | 3.50 | 4.00 | 2.00 | 1.50 | 1.00 | 0.30 |
| +0.10 | +0.05 | +0.05 | +0.10 | +0.15 | +0.10 | +0.10 | +0.05 | +0.10 | +0.10 | +0.05 |
| -0.10 | -0.05 | -0.05 | -0.10 | -0.10 | -0.10 | -0.10 | -0.05 | -0.00 | -0.00 | -0.05 |

Korea Sales Office (KOREA) +82)31-904-1444
 China Sales Office (CHINA) +86)0758-683-1444
 Hungary Sales office (EUROPE) +36)1-404-5832

H.K Sales Office (HONGKONG) +852)2711-5551
 LA Sales Office (USA) +1)714-616-6989

• You can also contact us by e-mail : coilmaster@coilmaster.com

- All specifications are subject to change without notice.
- Update date : 2023.08.10

www.coilmaster.com