

CMI-CSSP10050NF-820M

Features

- ▶ Magnetic shield type wound inductor for power circuits.
- ▶ Available tape and reel for auto insertion
- ▶ RoHS compliant
- ▶ AEC-Q200 qualified

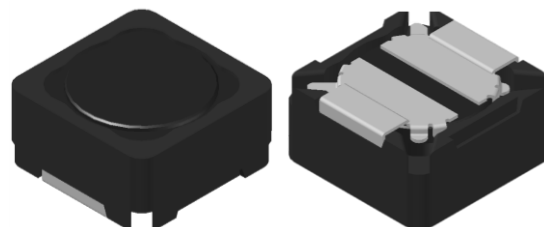

Applications

- ▶ Equipment using for automobiles
(ECM, Airbags, Headlights, Electronic Powder Steering, Motors, ABS, other)

Dimension (Unit:mm)

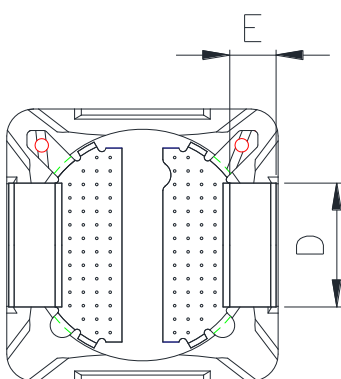
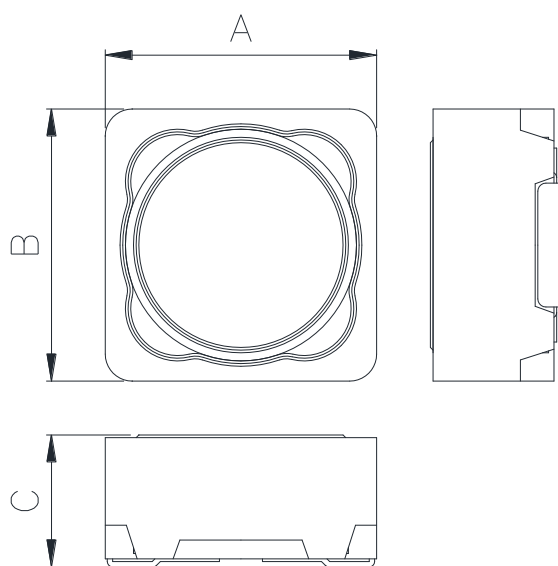

Land Pattern (Unit:mm)

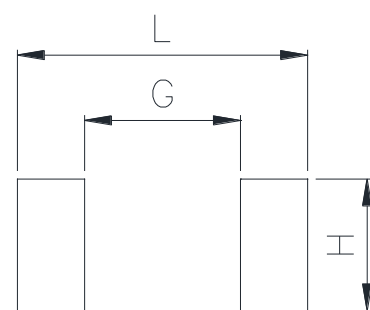

A	B	C	D	E	G	H	L
10.0 ±0.3	10.0 ±0.3	5.0 Max.	4.6 ±0.2	1.97 ±0.3	5.8	4.9	10.8

Regulation of part number

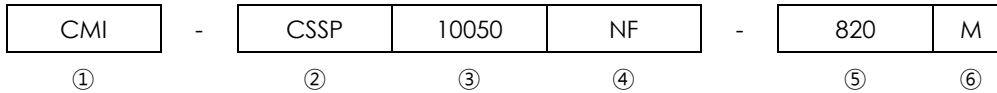

- ① CoilMaster's initial
- ② Series Name : Car Shielded core Square shape Pin type Power Inductor
- ③ Core Size (unit:mm)
- ④ Type
- ⑤ Typical inductance value (82uH)
- ⑥ Inductance tolerance ($\pm 20\%$)

Specifications

Part Number	Inductance (uH)	Tolerance (\pm)	DCR (mohm) Max.(Typ.)	Isat(A) Max.(Typ.)	Itemp(A) Max.(Typ.)	Test Frequency (Hz)
CMI-CSSP10050NF-820M	82	20%	150(125)	1.6(1.7)	2.0(2.1)	100k

- Isat: When based on the inductance change rate (Approximately 30% below in the initial value)
- Itemp: When based on the temperature increase (Temperature increase of approximately 40°C by self heating)
- Operating Temperature Range (including self temperature) : -40°C ~ +165 °c

Note 1 : Circuit design, component placement, PCB trace size and thickness, airflow and other cooling. Provision all affect the part Temperature. Part temperature should be verified in the end application.

Electrical characteristics

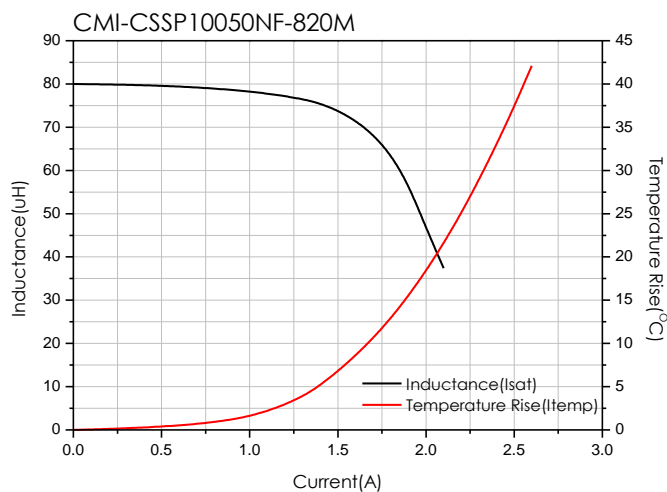

- You can also contact us by e-mail : coilmaster@coilmaster.com
- All specifications are subject to change without notice.
- Update date : 2023.05.10

Packaging

(1) Package quantity : 600 (pcs/reel)

(2) Reel Dimensions (unit:mm)

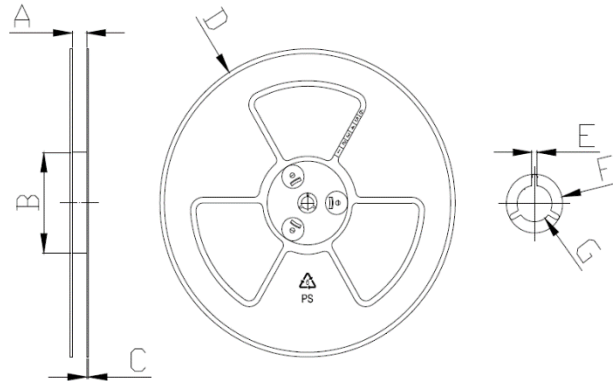

A	B	C	D	E	F	G
24.50	100.0	2.00	330.0	2.30	21.50	13.00
+0.50	+1.00	+0.10	+3.00	+0.30	+0.30	+0.50
-0.50	-1.00	-0.10	-3.00	-0.30	-0.30	-0.20

(3) Tape Dimensions

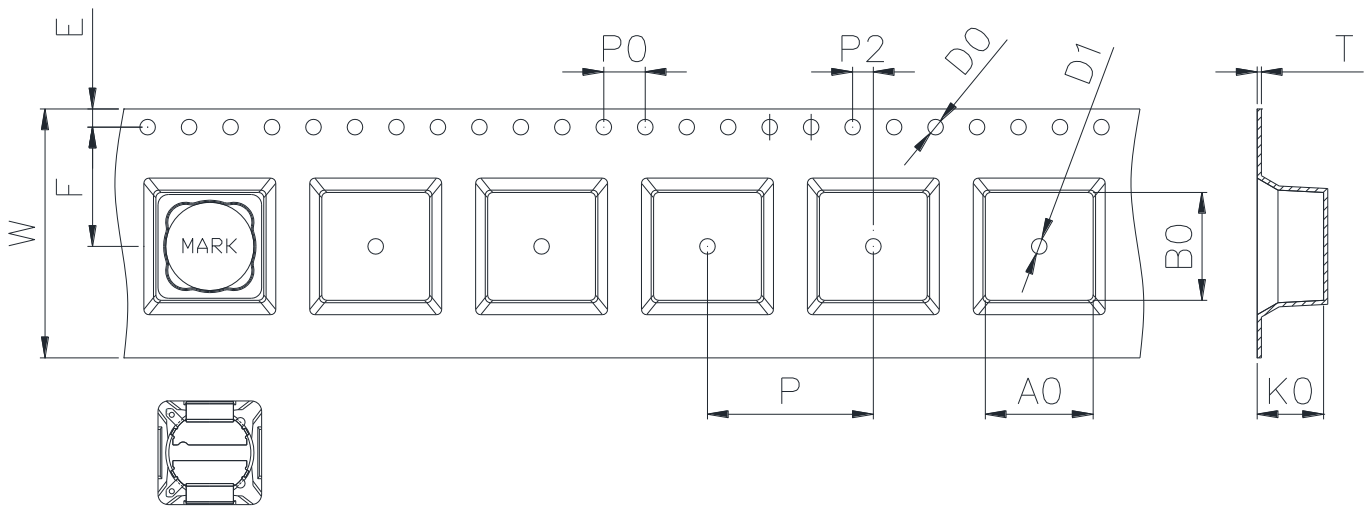

W	A0	B0	K0	E	F	P	P0	P2	D0/D1	T
24.00	10.30	10.30	4.70	1.75	11.50	16.00	4.00	2.00	1.50	0.40
+0.30	+0.10	+0.10	+0.10	+0.10	+0.10	+0.10	+0.10	+0.10	+0.10	+0.05
-0.10	-0.10	-0.10	-0.10	-0.10	-0.10	-0.10	-0.10	-0.10	-0.00	-0.05

Korea Sales Office (KOREA) +82)31-904-1444
 China Sales Office (CHINA) +86)0758-683-1444
 Hungary Sales office (EUROPE) +36)1-404-5832

H.K Sales Office (HONGKONG) +852)2711-5551
 LA Sales Office (USA) +1)714-616-6989

• You can also contact us by e-mail : coilmaster@coilmaster.com

- All specifications are subject to change without notice.
- Update date : 2023.05.10

www.coilmaster.com