

CMI-CSSP12080NF-SERIES

Features

- ▶ Magnetic shield type wound inductor for power circuits.
- ▶ Available tape and reel for auto insertion.
- ▶ RoHS compliant.
- ▶ AEC-Q200 qualified.

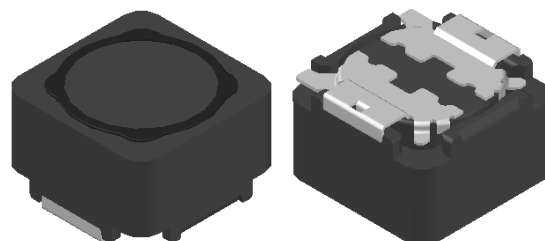

Applications

- ▶ Equipment using for automobiles
(ECM, Airbags, Headlights, Electronic Powder Steering, Motors, ABS, other)

Dimension (Unit:mm)

Land Pattern (Unit:mm)

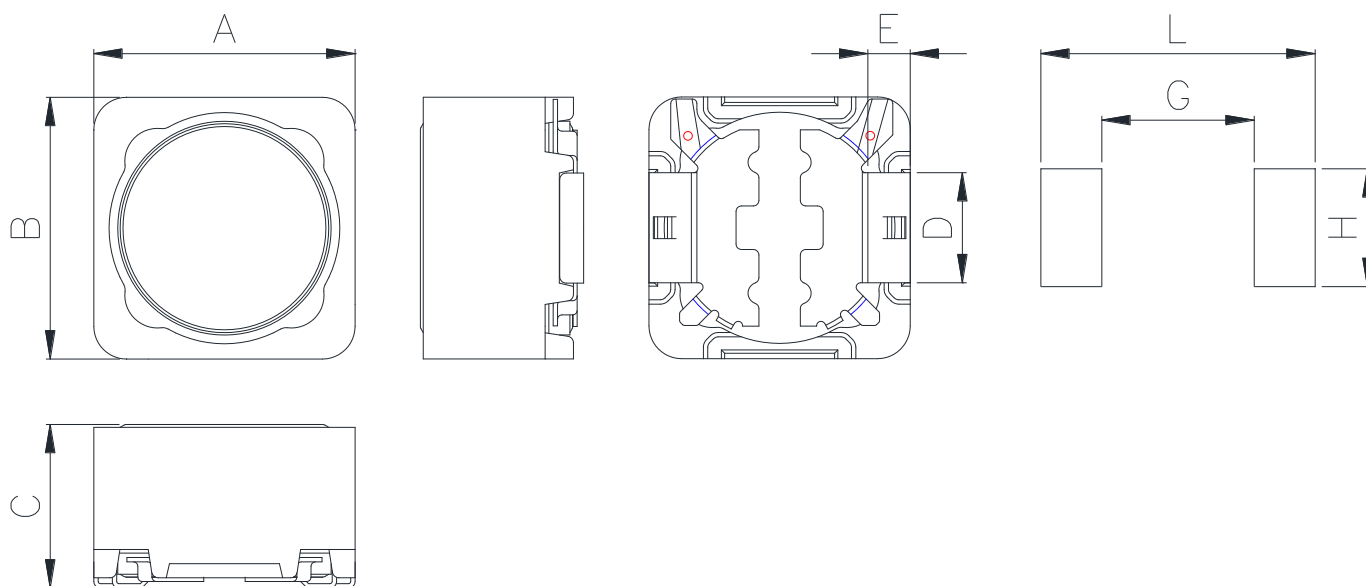

A	B	C	D	E	G	H	L
12.0 ±0.3	12.0 ±0.3	8.0 Max.	5.0 ±0.2	1.9 ±0.3	7.0	5.4	12.6

Regulation of part number

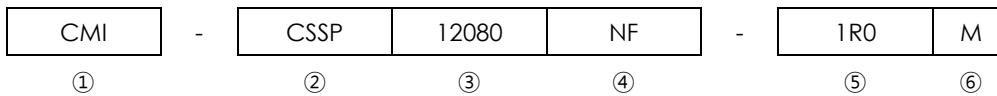

- ① CoilMaster's initial
- ② Series Name : Car Shielded core Square shape Pin type Power Inductor
- ③ Core Size (unit:mm)
- ④ Type
- ⑤ Typical inductance value (1.0uH)
- ⑥ Inductance tolerance ($\pm 20\%$)

Specifications

Part Number	Inductance (uH)	Tolerance (\pm)	DCR (mohm) Max.(Typ.)	Isat(A) Max.(Typ.)	Itemp(A) Max.(Typ.)	Test Frequency (Hz)
CMI-CSSP12080NF-1R0M	1.0	20%	10.1(7)	18.00(20.00)	16.00(17.00)	100k
CMI-CSSP12080NF-1R2M	1.2	20%	11(8.5)	15.50(16.00)	13.00(13.50)	100k
CMI-CSSP12080NF-2R2M	2.2	20%	11.7(9)	11.50(12.00)	12.00(12.50)	100k
CMI-CSSP12080NF-3R9M	3.9	20%	15.6(13)	11.00(11.50)	9.80(10.20)	100k
CMI-CSSP12080NF-4R7M	4.7	20%	16.8(14)	10.50(11.00)	9.30(9.70)	100k
CMI-CSSP12080NF-6R8M	6.8	20%	25.2(16)	10.00(10.50)	9.20(9.60)	100k
CMI-CSSP12080NF-8R2M	8.2	20%	21.6(18)	9.00(9.50)	8.80(9.10)	100k
CMI-CSSP12080NF-100M	10	20%	24(20)	8.70(9.20)	8.50(8.90)	100k
CMI-CSSP12080NF-150M	15	20%	38(32)	6.90(7.20)	6.80(7.10)	100k
CMI-CSSP12080NF-220M	22	20%	42(35)	5.30(5.60)	5.50(5.90)	100k
CMI-CSSP12080NF-250M	25	20%	50.4(42)	5.20(5.50)	5.30(5.70)	100k
CMI-CSSP12080NF-330M	33	20%	54(45)	4.50(4.80)	4.80(5.30)	100k
CMI-CSSP12080NF-450M	45	20%	69.6(58)	4.30(4.60)	4.60(4.90)	100k
CMI-CSSP12080NF-470M	47	20%	72(60)	3.60(3.90)	4.40(4.70)	100k
CMI-CSSP12080NF-560M	56	20%	84(70)	3.50(3.80)	4.00(4.30)	100k
CMI-CSSP12080NF-680M	68	20%	90(80)	3.20(3.50)	3.50(3.90)	100k
CMI-CSSP12080NF-820M	82	20%	80.4(67)	3.00(3.30)	3.40(3.70)	100k
CMI-CSSP12080NF-101M	100	20%	150(125)	2.80(3.00)	3.30(3.60)	100k
CMI-CSSP12080NF-121M	120	20%	168(140)	2.60(2.80)	2.90(3.20)	100k
CMI-CSSP12080NF-151M	150	20%	276(230)	2.30(2.40)	2.40(2.60)	100k

• You can also contact us by e-mail : coilmaster@coilmaster.com

- All specifications are subject to change without notice.
- Update date : 2024.04.30

www.coilmaster.com

Part Number	Inductance (uH)	Tolerance (±)	DCR (mohm) Max.(Typ.)	Isat(A) Max.(Typ.)	Itemp(A) Max.(Typ.)	Test Frequency (Hz)
CMI-CSSP12080NF-221M	220	20%	336(280)	1.90(2.10)	2.10(2.30)	100k
CMI-CSSP12080NF-271M	270	20%	384(320)	1.75(1.85)	2.00(2.20)	100k
CMI-CSSP12080NF-331M	330	20%	474(395)	1.40(1.60)	1.80(2.00)	100k
CMI-CSSP12080NF-471M	470	20%	624(520)	1.35(1.45)	1.60(1.80)	100k
CMI-CSSP12080NF-681M	680	20%	870(725)	1.15(1.25)	1.40(1.60)	100k
CMI-CSSP12080NF-821M	820	20%	1068(890)	1.00(1.10)	1.30(1.50)	100k
CMI-CSSP12080NF-102M	1000	20%	1620(1350)	0.90(1.00)	1.20(1.30)	100k

- Isat: When based on the inductance change rate (Approximately 30% below in the initial value)
- Itemp: When based on the temperature increase (Temperature increase of approximately 40°C by self heating)
- Operating Temperature Range (including self temperature) : -40°C ~ +165 °c

Note 1 : Circuit design, component placement, PCB trace size and thickness, airflow and other cooling. Provision all affect the part Temperature. Part temperature should be verified in the end application.

Electrical characteristics

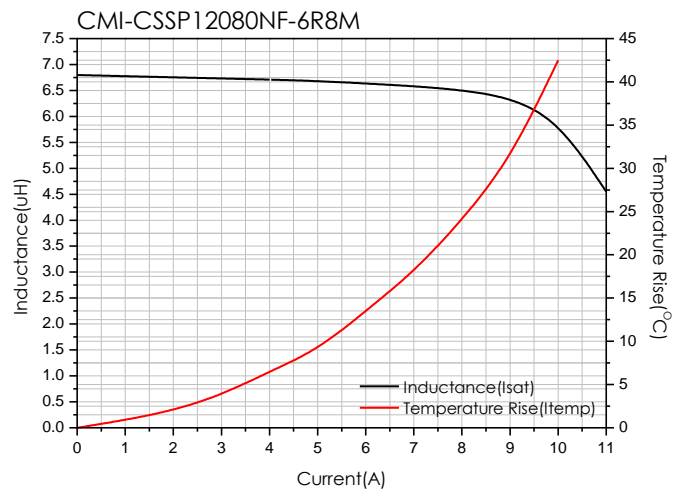
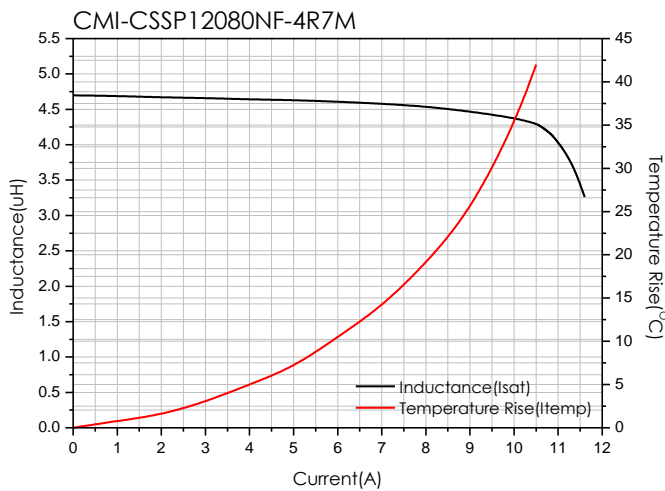
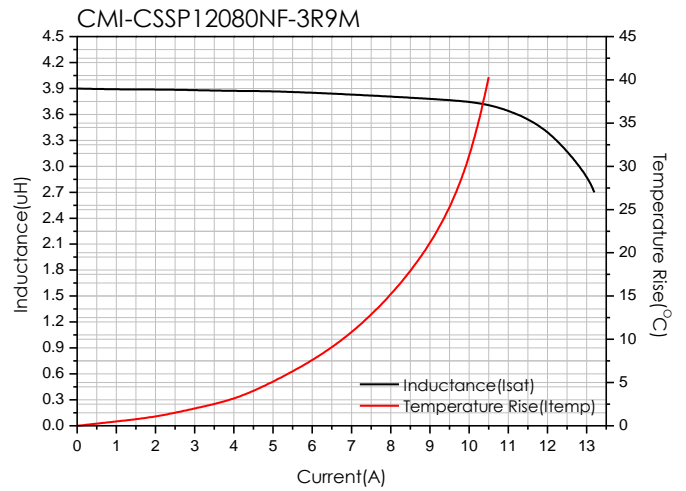
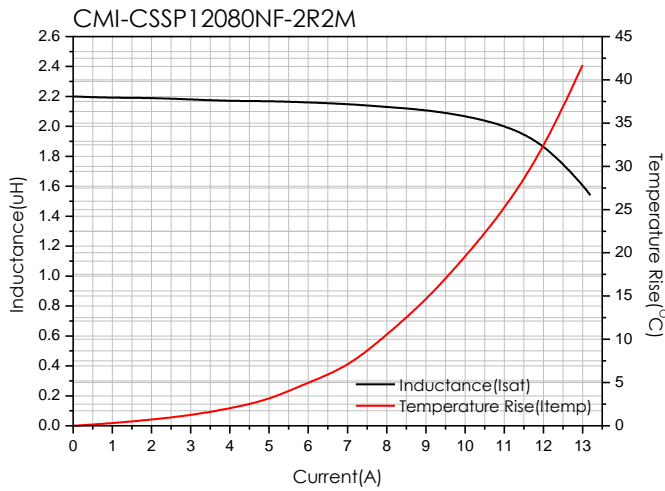
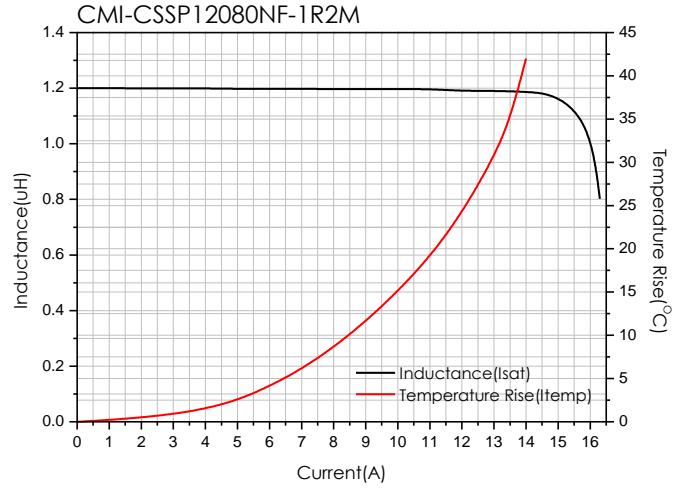
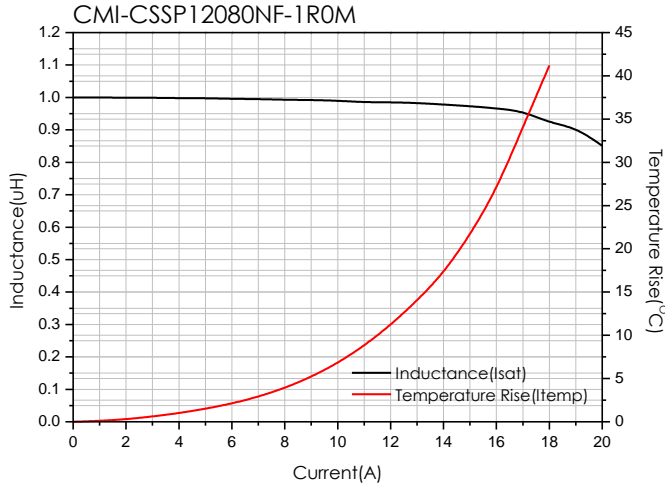

- You can also contact us by e-mail : coilmaster@coilmaster.com
- All specifications are subject to change without notice.
- Update date : 2024.04.30

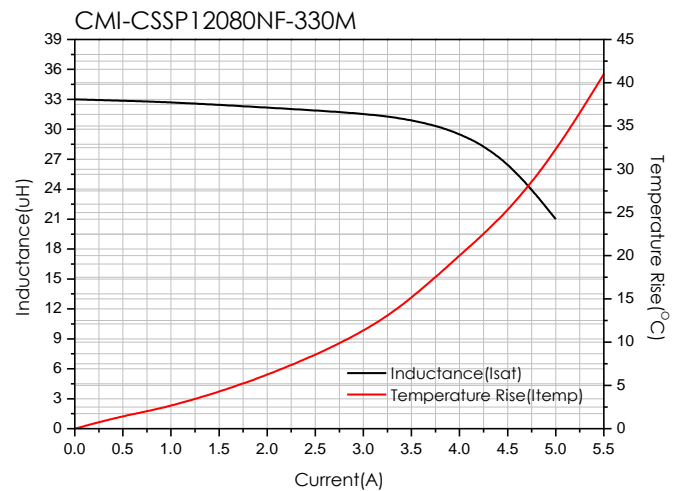
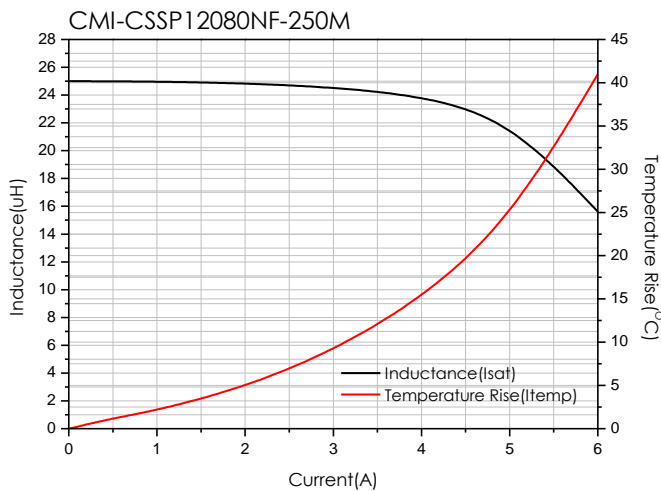
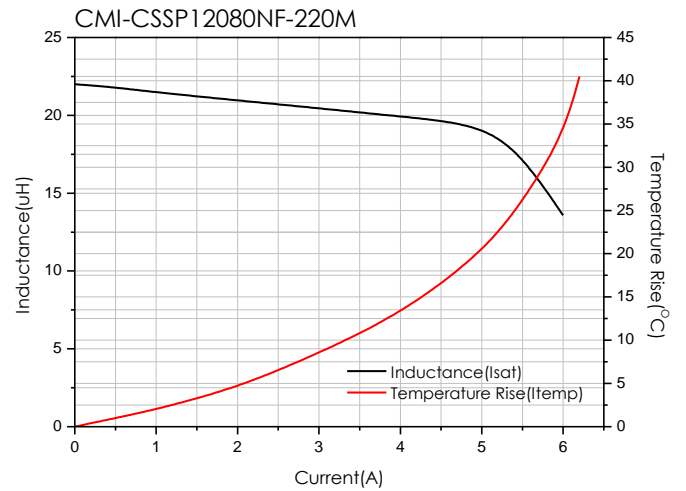
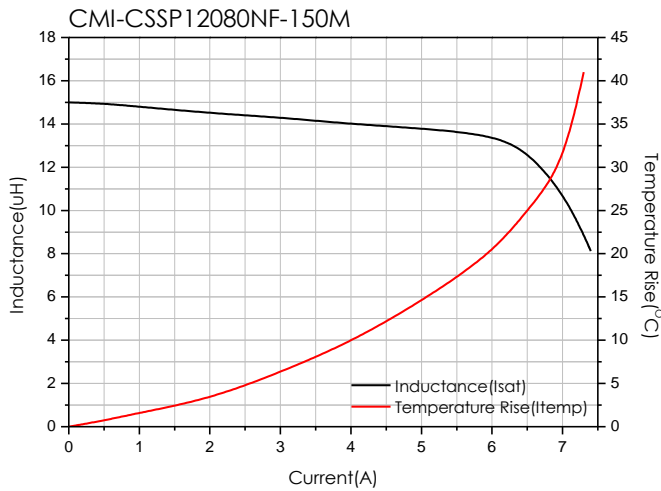
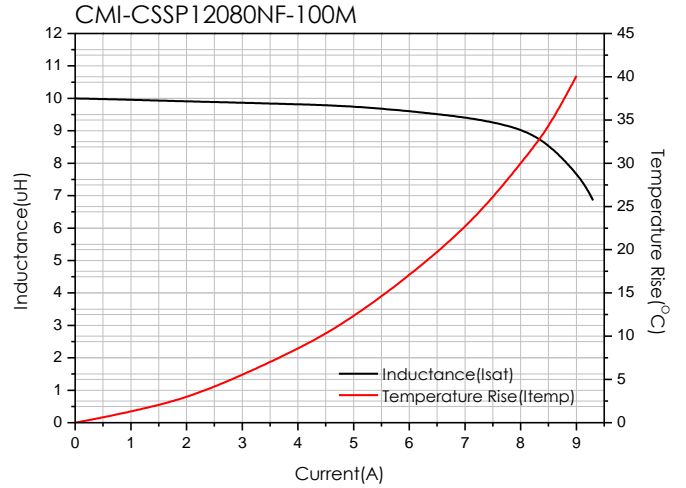
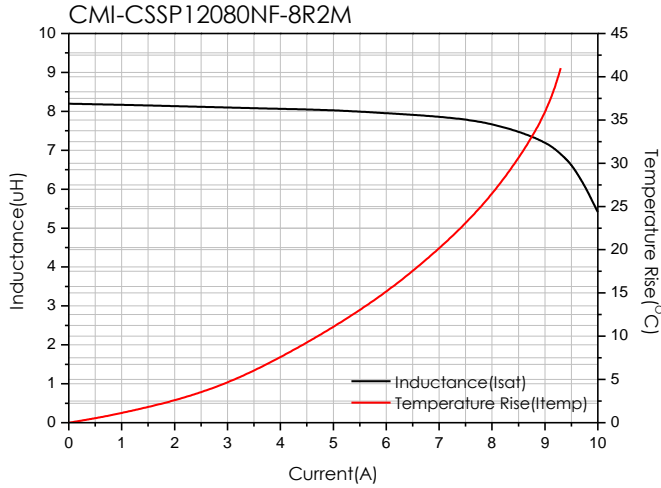

- You can also contact us by e-mail : coilmaster@coilmaster.com
- All specifications are subject to change without notice.
- Update date : 2024.04.30

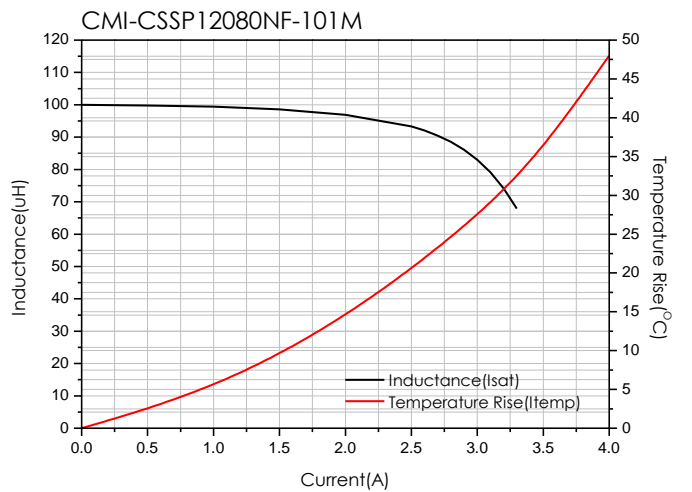
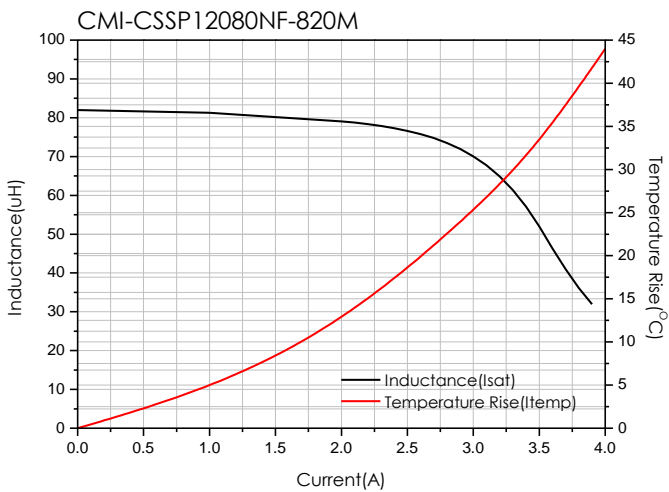
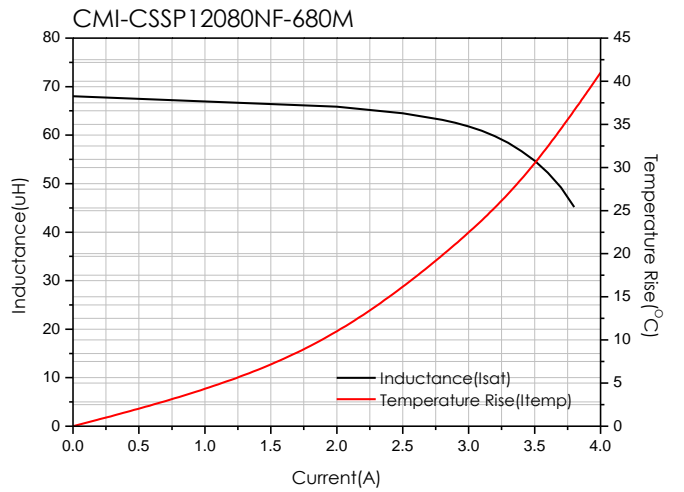
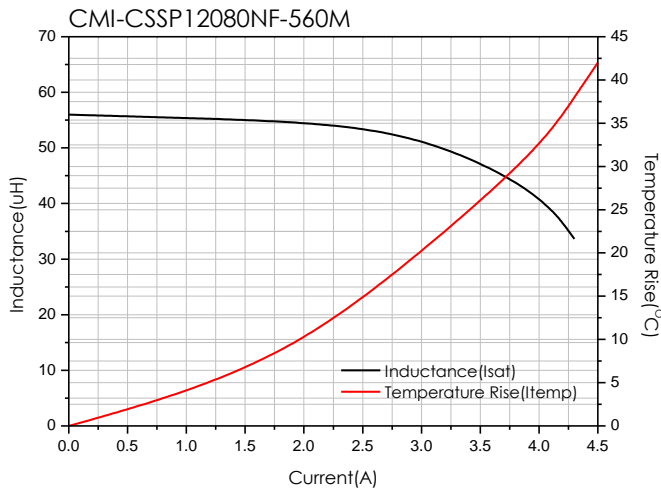
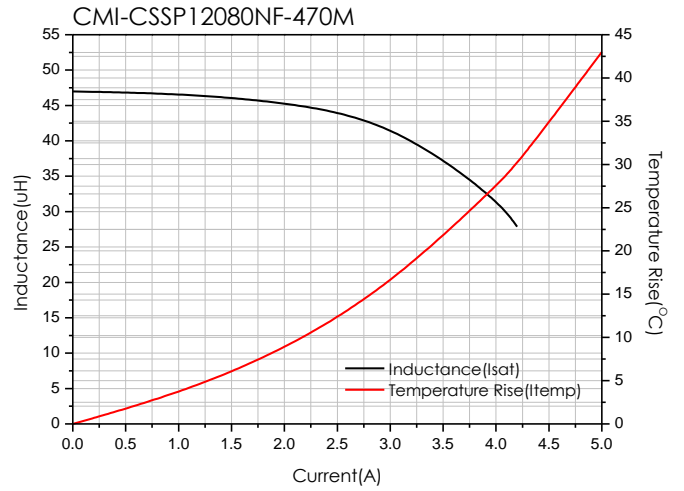
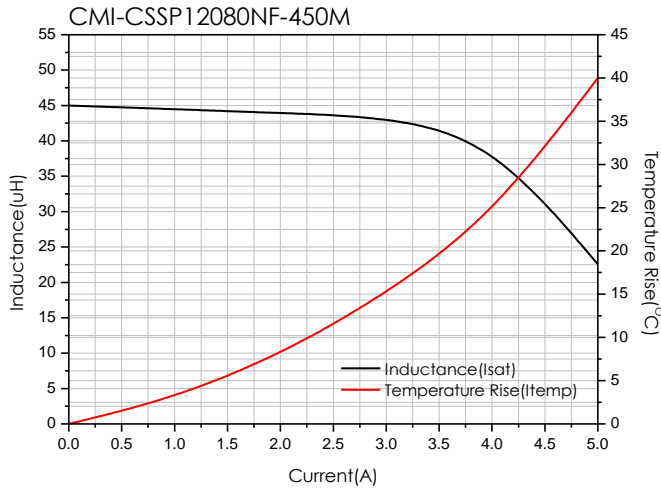

- You can also contact us by e-mail : coilmaster@coilmaster.com
- All specifications are subject to change without notice.
- Update date : 2024.04.30

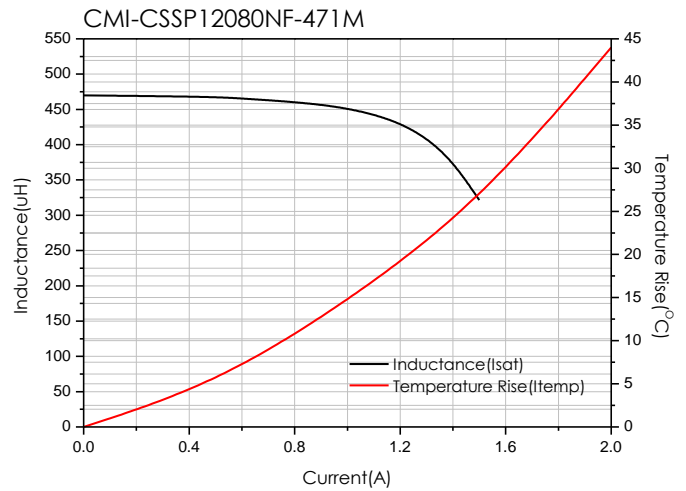
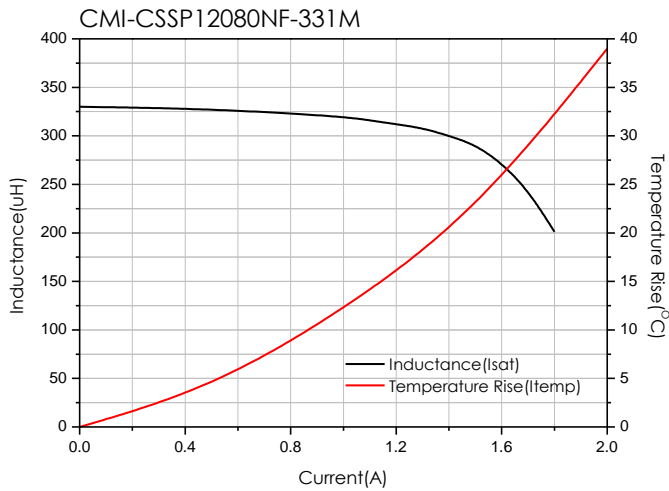
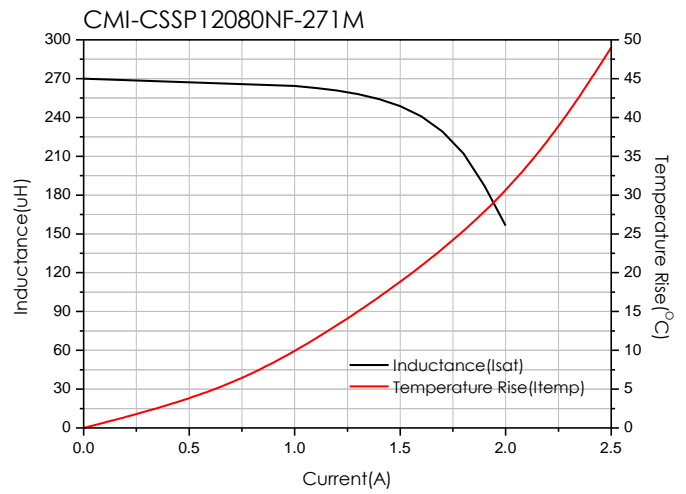
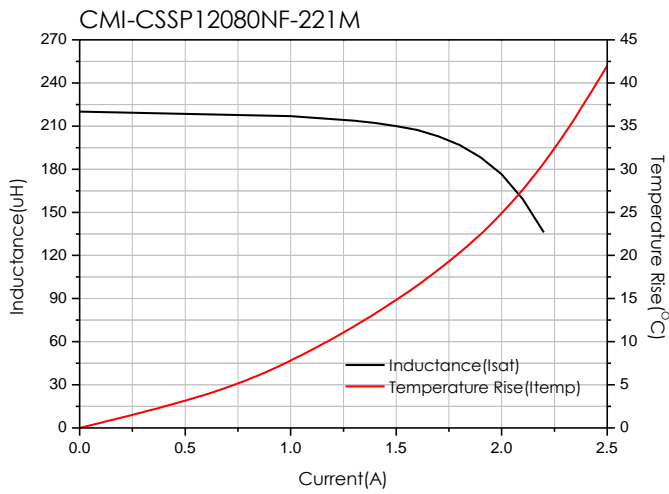
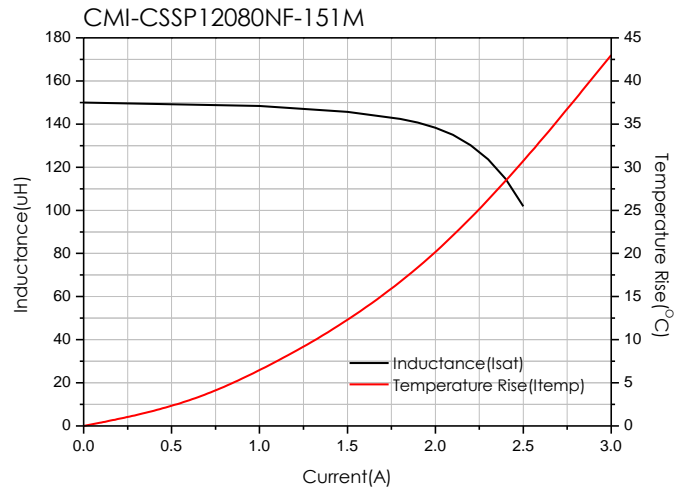
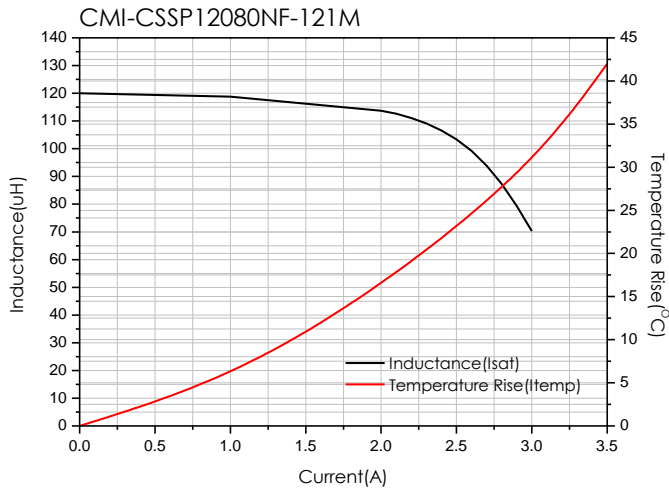

- You can also contact us by e-mail : coilmaster@coilmaster.com
- All specifications are subject to change without notice.
- Update date : 2024.04.30

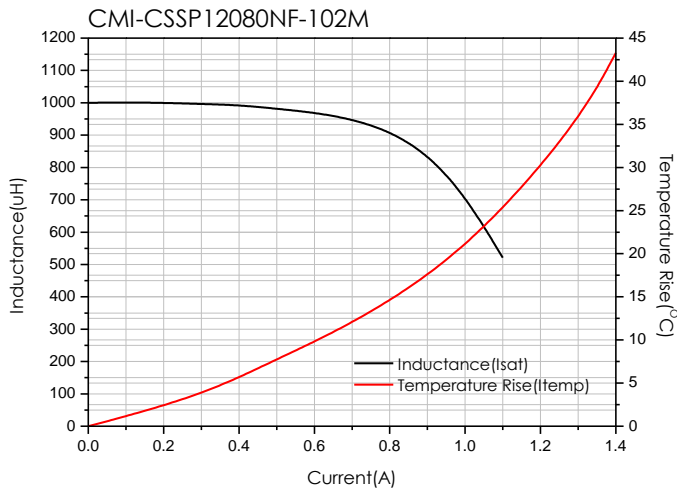
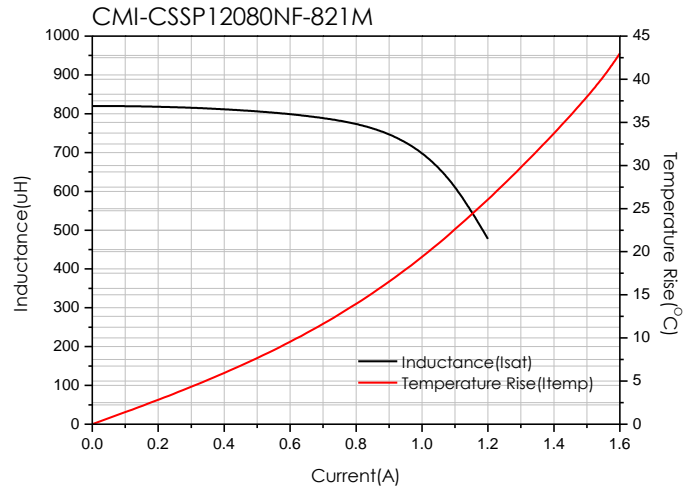
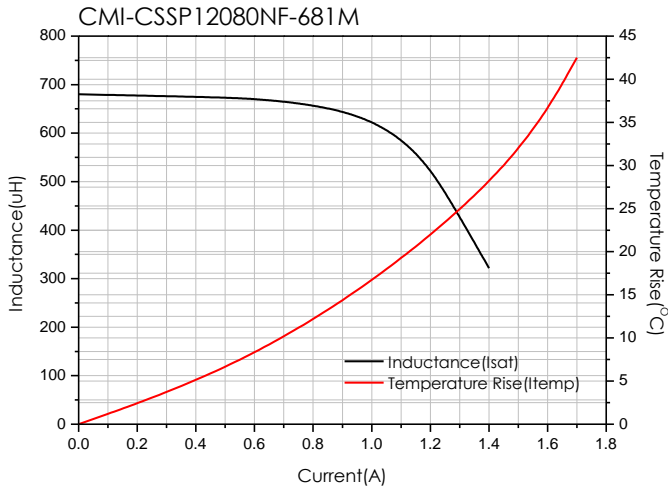

- You can also contact us by e-mail : coilmaster@coilmaster.com
- All specifications are subject to change without notice.
- Update date : 2024.04.30

Packaging

(1) Package quantity : 500 (pcs/reel)

(2) Reel Dimensions (unit:mm)

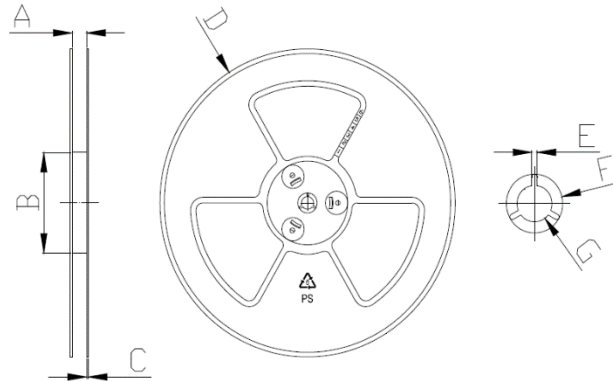

A	B	C	D	E	F	G
24.50	100.0	2.30	330.0	2.30	21.50	13.00
+0.50	+1.00	+0.20	+3.00	+0.30	+0.20	+0.40
-0.50	-1.00	-0.20	-3.00	-0.30	-0.20	-0.40

(3) Tape Dimensions

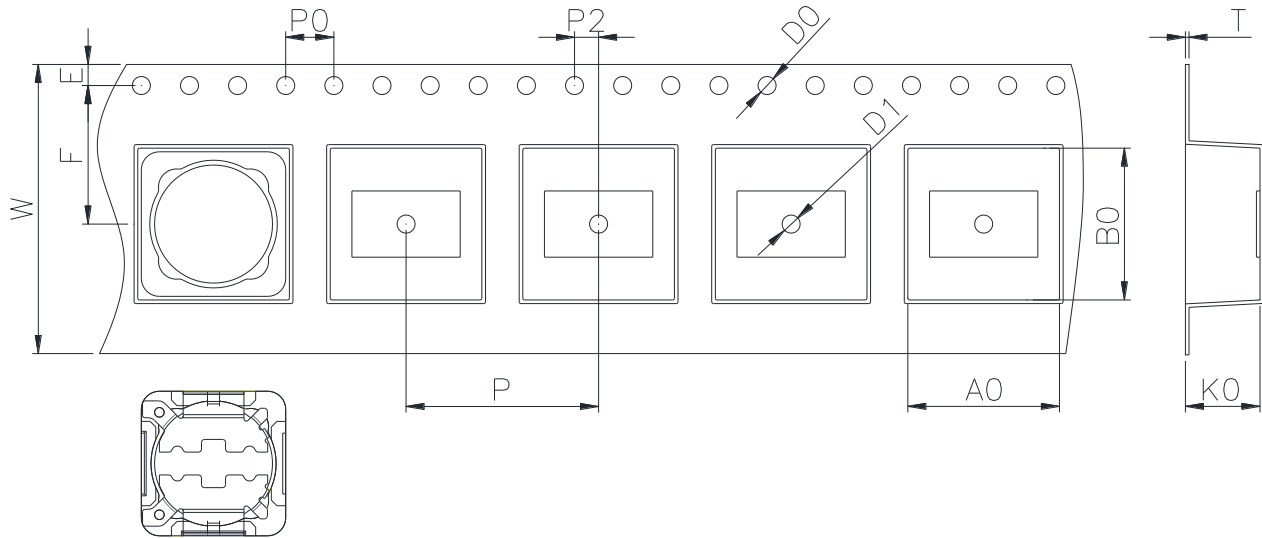

W	A0	B0	K0	E	F	P	P0	P2	D0/D1	T
24.00	12.60	12.60	8.30	1.75	11.50	16.00	4.00	2.00	1.50	0.40
+0.30	+0.10	+0.10	+0.10	+0.10	+0.10	+0.10	+0.10	+0.10	+0.10	+0.05
-0.10	-0.10	-0.10	-0.10	-0.10	-0.10	-0.10	-0.10	-0.10	-0.00	-0.05

Korea Sales Office (KOREA) +82)31-904-1444
 China Sales Office (CHINA) +86)0758-683-1444
 Hungary Sales office (EUROPE) +36)1-404-5832

H.K Sales Office (HONGKONG) +852)2711-5551
 LA Sales Office (USA) +1)714-616-6989

• You can also contact us by e-mail : coilmaster@coilmaster.com

- All specifications are subject to change without notice.
- Update date : 2024.04.30

www.coilmaster.com