

CMI-CSSP6040NF-SERIES

Features

- ▶ Magnetic shield type wound inductor for power circuits.
- ▶ Available tape and reel for auto insertion
- ▶ RoHS compliant
- ▶ AEC-Q200 qualified

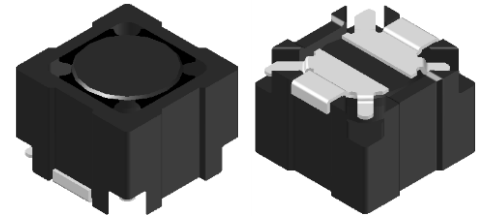

Applications

- ▶ Equipment using for automobiles
(ECM, Airbags, Headlights, Electronic Powder Steering, Motors, ABS, other)

Dimension (Unit:mm)

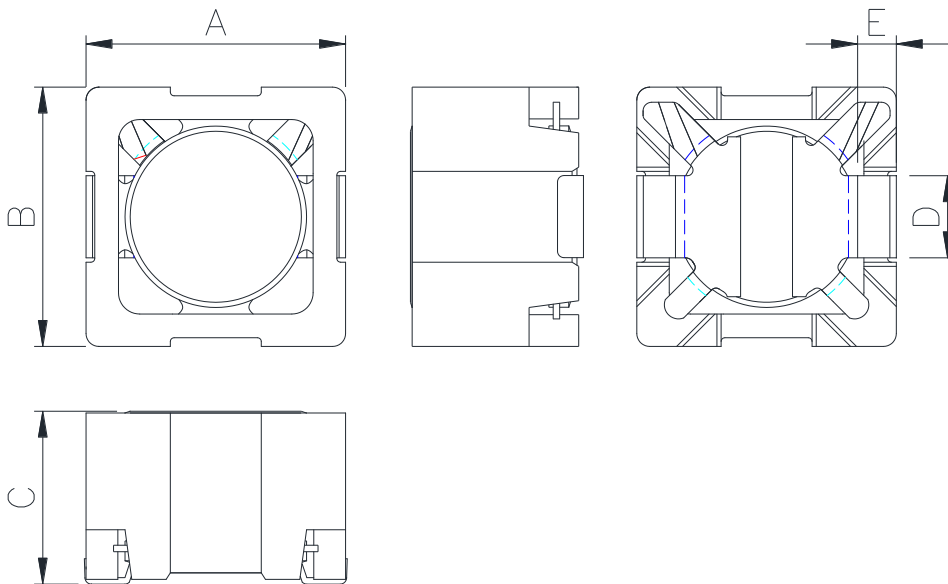

Land Pattern (Unit:mm)

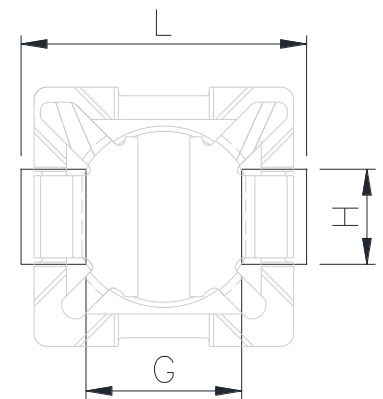

A	B	C	D	E
6.0 ±0.3	6.0 ±0.3	4.0 Max.	1.9 ±0.2	0.9 ±0.2

G	H	L
3.6	2.2	6.6

- You can also contact us by e-mail: coilmaster@coilmaster.com
- All specifications are subject to change without notice.
- Update date: 2026.06.16 (Rev.0.0)

Packaging

(1) Package quantity: 1,000 (pcs/reel)

(2) Reel Dimensions (unit:mm)

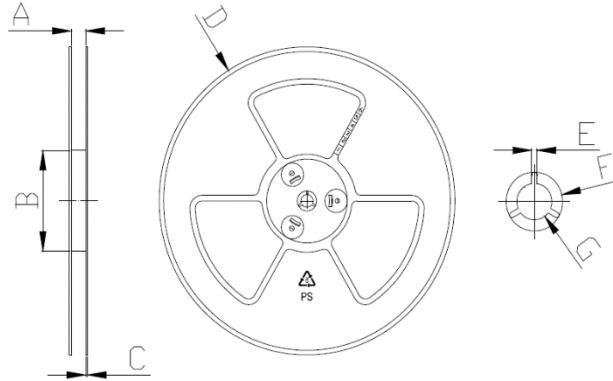

A	B	C	D	E	F	G
16.50	100.0	2.00	330.0	2.30	21.50	13.00
+0.50	+1.00	+0.10	+3.00	+0.30	+0.30	+0.50
-0.50	-1.00	-0.10	-3.00	-0.30	-0.30	-0.20

(3) Tape Dimensions

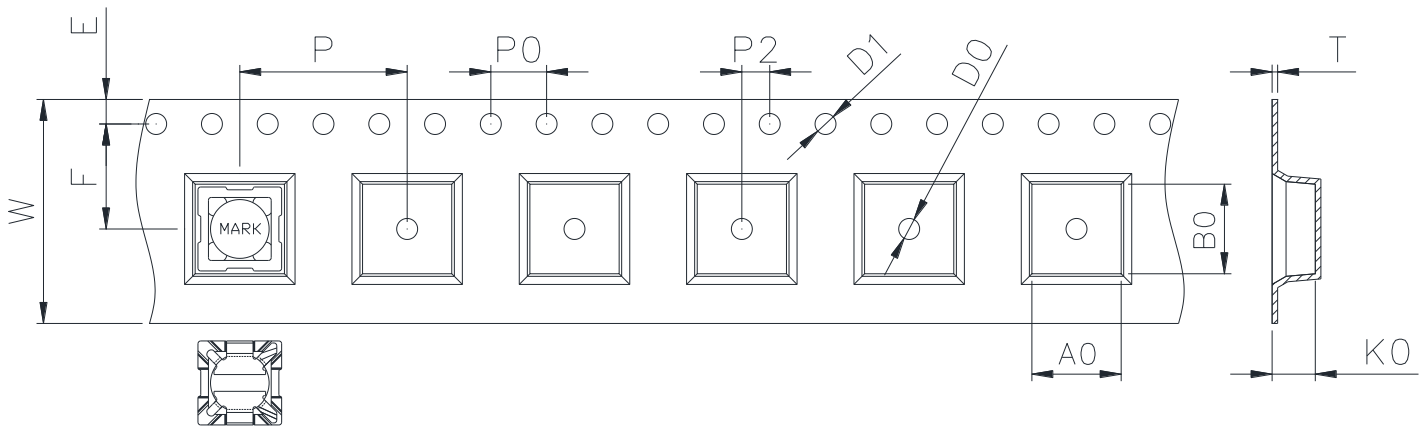

W	A0	B0	K0	E	F	P	P0	P2	D0/D1	T
16.00	6.40	6.40	4.80	1.75	7.50	12.00	4.00	2.00	1.50	0.40
+0.30	+0.10	+0.10	+0.10	+0.10	+0.10	+0.10	+0.10	+0.10	+0.10	+0.05
-0.10	-0.10	-0.10	-0.10	-0.10	-0.10	-0.10	-0.10	-0.10	-0.00	-0.05

Korea Sales Office (KOREA) +82)31-904-1444
 China Sales Office (CHINA) +86)0758-683-1444
 Hungary Sales office (EUROPE) +36)1-404-5832

H.K Sales Office (HONGKONG) +852)2711-5551
 LA Sales Office (USA) +1)714-616-6989

- You can also contact us by e-mail: coilmaster@coilmaster.com
- All specifications are subject to change without notice.
- Update date: 2026.06.16 (Rev.0.0)