

# CMI-DP4012NH-SERIES

## Features

- ▶ SMD inductor.
- ▶ Resin shielded construction.
- ▶ Available tape and reel for auto insertion.
- ▶ RoHS compliant
- ▶ Halogen-Free

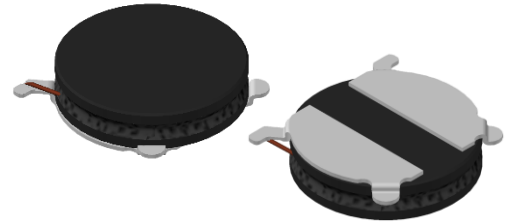

## Applications

- ▶ For small DC/DC converter (LCD/LED/OLED display, HDD, DSC etc).
- ▶ For Power supply circuits.

## Dimension (Unit:mm)

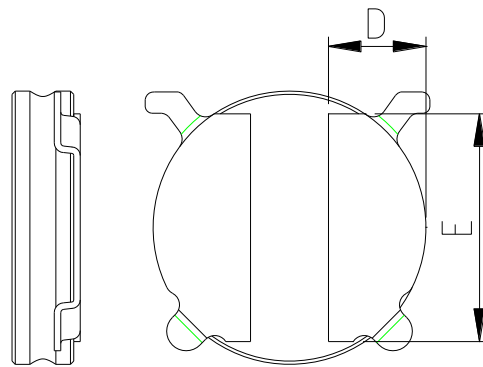
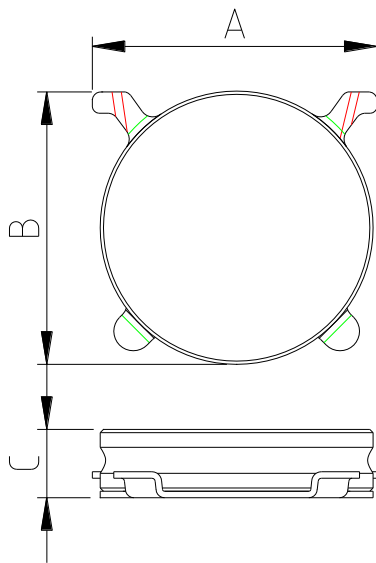

## Land Pattern (Unit:mm)

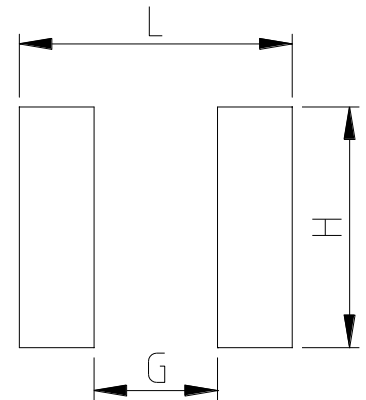

A	B	C	D	E	G	H	L
4.0 ±0.2	4.0 ±0.2	1.2 Max.	1.5 ±0.2	3.5 ±0.2	1.9	3.7	4.2

- You can also contact us by e-mail : [coilmaster@coilmaster.com](mailto:coilmaster@coilmaster.com)
- All specifications are subject to change without notice.
- Update date : 2015.11.19

## Regulation of part number

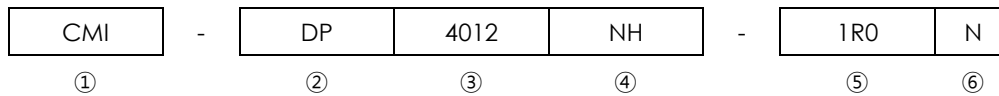

- ① CoilMaster's initial
- ② Series Name : Drum core Pin type Power inductor
- ③ Core Size (unit:mm)
- ④ Type
- ⑤ Typical inductance value (1.0uH)
- ⑥ Inductance tolerance (±30%)

## Specifications

Part Number	Inductance (uH)	Tolerance (±)	DCR (mohm) Max.(Typ.)	Isat(A) Max.	Itemp(A) Max.	Test Frequency (Hz)
CMI-DP4012NH-1R0M	1.0	20%	60(50)	2.80	2.60	100k
CMI-DP4012NH-1R5M	1.5	20%	78(65)	2.30	2.10	100k
CMI-DP4012NH-2R2M	2.2	20%	9.6(80)	2.10	2.00	100k
CMI-DP4012NH-3R3M	3.3	20%	132(110)	1.80	1.50	100k
CMI-DP4012NH-4R7M	4.7	20%	150(125)	1.40	1.20	100k
CMI-DP4012NH-6R8M	6.8	20%	234(195)	1.10	1.00	100k
CMI-DP4012NH-100M	10	20%	318(265)	0.90	0.80	100k
CMI-DP4012NH-150M	15	20%	408(340)	0.72	0.70	100k
CMI-DP4012NH-220M	22	20%	702(585)	0.52	0.50	100k

- Isat: When based on the inductance change rate (approximately 20% below in the initial value)
- Itemp: When based on the temperature increase (Temperature increase of approximately 40°C by self heating)
- Operating Temperature Range(including self temperature) : -40°C ~ +125 °C

Note 1 : Circuit design, component placement, PCB trace size and thickness, airflow and other cooling. Provision all affect the part Temperature. Part temperature should be verified in the end application.

---

Korea Sales Office (KOREA)	+82)31-904-1444	H.K Sales Office (HONGKONG)	+852)2711-5551
China Sales Office (CHINA)	+86)0758-683-1444	LA Sales Office (USA)	+1)714-616-6989
Hungary Sales office (EUROPE)	+36)1-404-5832		

▪ **You can also contact us by e-mail : [coilmaster@coilmaster.com](mailto:coilmaster@coilmaster.com)**

- All specifications are subject to change without notice.
- Update date : 2015.11.19

[www.coilmaster.com](http://www.coilmaster.com)