

# CMI-DSS4030NH-SERIES

## Features

- ▶ It corresponds to High current.
- ▶ Simple and Shield structure.
- ▶ Takes up less PCB real estate and save more power.
- ▶ Available tape and reel for auto insertion.
- ▶ RoHs compliant.
- ▶ Halogen-Free.

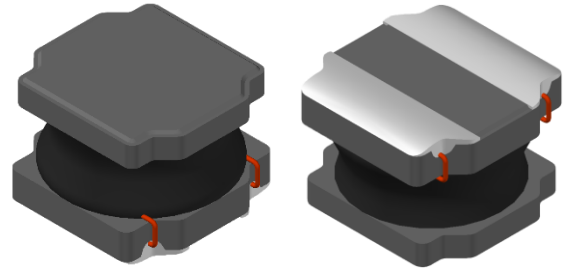

## Applications

- ▶ For small DC/DC converter (cellular Phone, LCD/LED/OLED display etc).

## Dimension (Unit:mm)

## Land Pattern (Unit:mm)

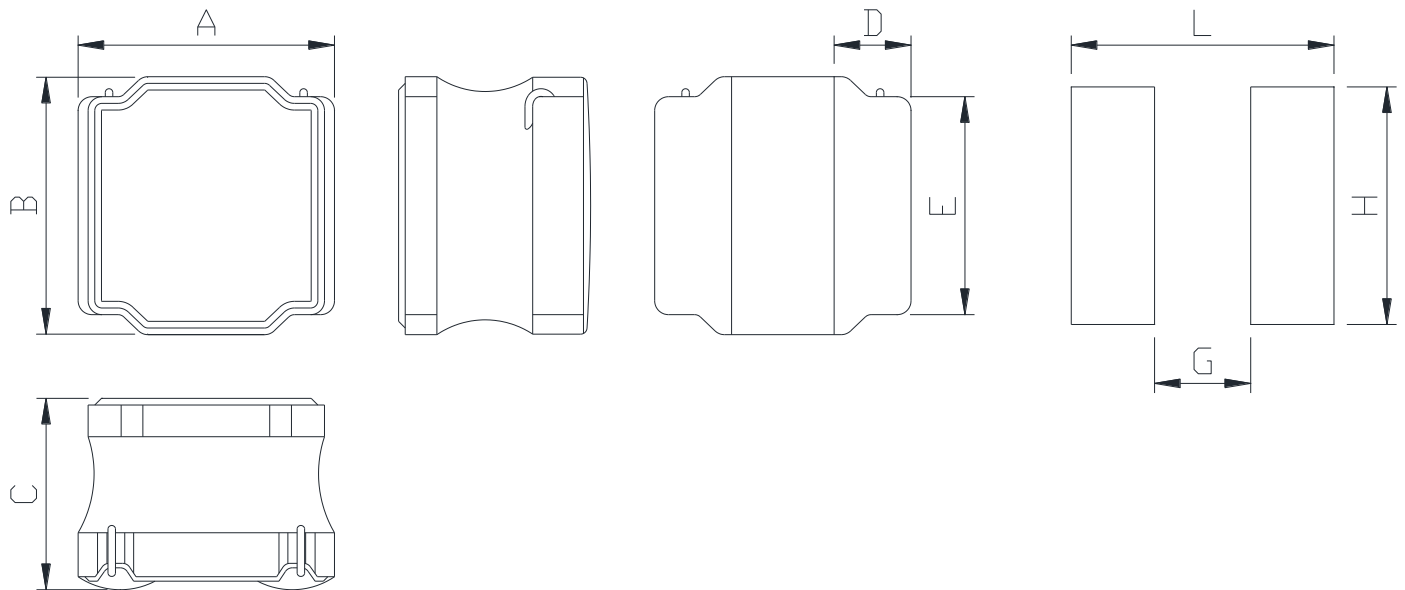

A	B	C	D	E	G	H	L
4.0 ±0.2	4.0 ±0.2	3.0 Max.	1.2 ±0.2	3.4 ±0.2	1.5	3.7	4.1

• You can also contact us by e-mail : [coilmaster@coilmaster.com](mailto:coilmaster@coilmaster.com)  
 • All specifications are subject to change without notice  
 • Update date : 2022.08.26

## Regulation of part number

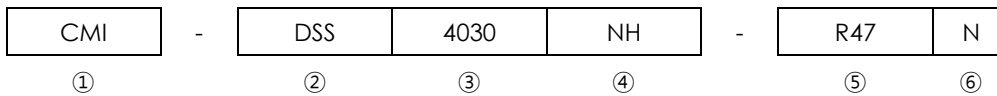

- ① CoilMaster's initial
- ② Series Name : Drum core Square shape Silver paste power inductor
- ③ Core Size (unit:mm)
- ④ Type
- ⑤ Typical inductance value (0.47uH)
- ⑥ Inductance tolerance ( $\pm 30\%$ )

## Specifications

Part Number	Inductance ( $\mu\text{H}$ )	Tolerance ( $\pm$ )	DCR(m $\Omega$ ) $\pm 30\%$	Isat(A) Max.	Itemp(A) Max.	Test Frequency [Hz]
CMI-DSS4030NH-R47N	0.47	30%	11	7.50	4.00	100k
CMI-DSS4030NH-R56N	0.56	30%	14	6.00	4.00	100k
CMI-DSS4030NH-1R0N	1.0	30%	15	5.90	3.40	100k
CMI-DSS4030NH-1R5N	1.5	30%	25	4.85	3.30	100k
CMI-DSS4030NH-1R8N	1.8	30%	30	4.25	3.20	100k
CMI-DSS4030NH-2R2M	2.2	20%	35	4.10	2.95	100k
CMI-DSS4030NH-3R3M	3.3	20%	40	3.30	2.40	100k
CMI-DSS4030NH-3R6M	3.6	20%	53	3.10	2.30	100k
CMI-DSS4030NH-3R9M	3.9	20%	57	3.00	2.10	100k
CMI-DSS4030NH-4R7M	4.7	20%	60	2.90	2.00	100k
CMI-DSS4030NH-5R6M	5.6	20%	70	2.75	1.95	100k
CMI-DSS4030NH-6R8M	6.8	20%	75	2.60	1.70	100k
CMI-DSS4030NH-7R5M	7.5	20%	90	2.20	1.65	100k
CMI-DSS4030NH-8R2M	8.2	20%	100	2.10	1.60	100k
CMI-DSS4030NH-100M	10	20%	115	1.95	1.50	100k
CMI-DSS4030NH-120M	12	20%	140	1.70	1.35	100k
CMI-DSS4030NH-150M	15	20%	190	1.65	1.15	100k
CMI-DSS4030NH-180M	18	20%	215	1.40	1.10	100k
CMI-DSS4030NH-220M	22	20%	225	1.30	1.00	100k
CMI-DSS4030NH-330M	33	20%	330	1.10	0.84	100k

• You can also contact us by e-mail : [coilmaster@coilmaster.com](mailto:coilmaster@coilmaster.com)

- All specifications are subject to change without notice
- Update date : 2022.08.26



## Packaging

(1) Package quantity : 2,000 (pcs/reel)

(2) Reel Dimensions (unit:mm)

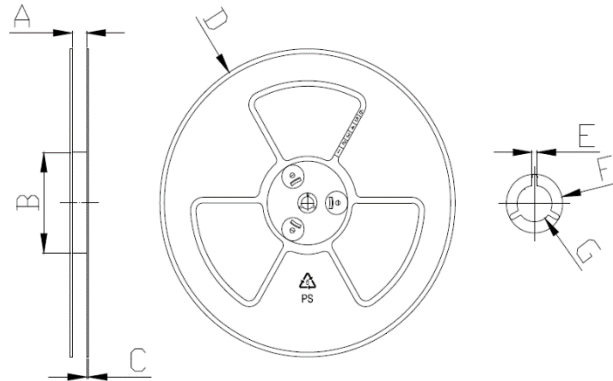

A	B	C	D	E	F	G
12.50	100.0	2.00	330.0	2.30	21.50	13.00
+0.50	+1.00	+0.10	+1.00	+0.30	+0.30	+0.50
-0.50	-1.00	-0.10	-1.00	-0.30	-0.30	-0.50

(3) Tape Dimensions

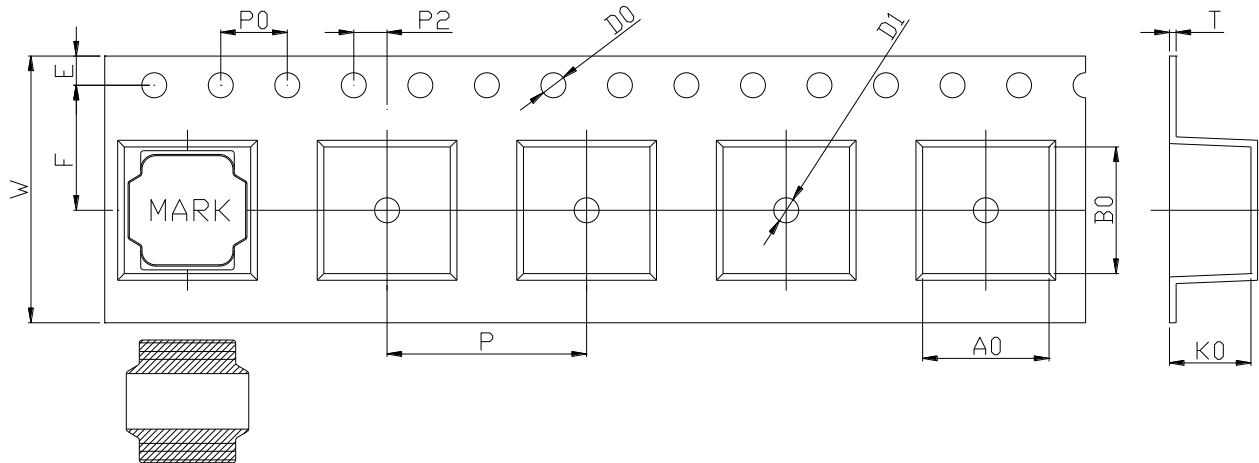

W	A0	B0	K0	E	F	P	P0	P2	D0/D1	T
12.00	4.30	4.30	3.40	1.75	5.50	8.00	4.00	2.00	1.50	0.30
+0.30	+0.10	+0.10	+0.10	+0.10	+0.10	+0.10	+0.10	+0.10	+0.10	+0.05
-0.10	-0.10	-0.10	-0.10	-0.10	-0.10	-0.10	-0.10	-0.10	-0.00	-0.05

Korea Sales Office (KOREA) +82)31-904-1444  
 China Sales Office (CHINA) +86)0758-683-1444  
 Hungary Sales office (EUROPE) +36)1-404-5832

H.K Sales Office (HONGKONG) +852)2711-5551  
 LA Sales Office (USA) +1)714-616-6989

• You can also contact us by e-mail : [coilmaster@coilmaster.com](mailto:coilmaster@coilmaster.com)

- All specifications are subject to change without notice
- Update date : 2022.08.26

[www.coilmaster.com](http://www.coilmaster.com)