

CMI-SSP10048NH-SERIES

Features

- ▶ SMD Inductor
- ▶ It corresponds to high current
- ▶ Simple and Shield structure
- ▶ Available tape and reel for auto insertion
- ▶ RoHs compliant.
- ▶ Halogen Free.

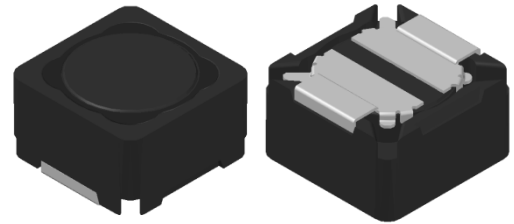

Applications

- ▶ For small DC/DC converter (LCD/LED/OLED TV, PC, SETOP etc)
- ▶ For Power supply circuits

Dimension (Unit:mm)

Land Pattern (Unit:mm)

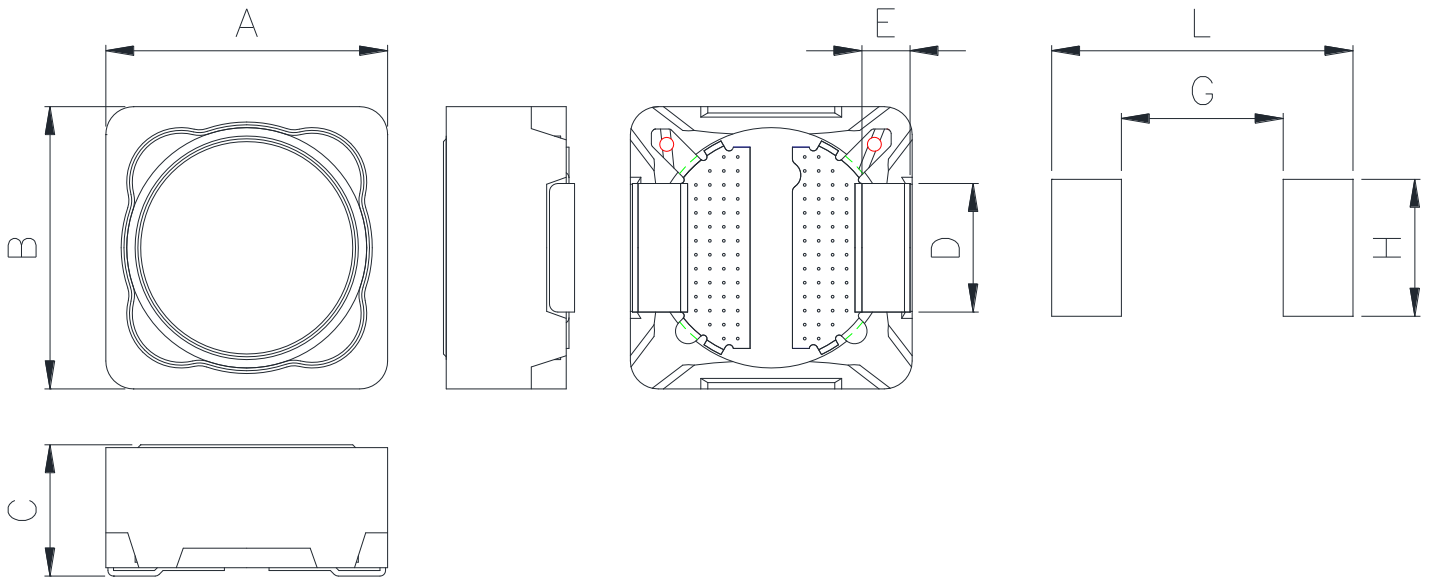

A	B	C	D	E	G	H	L
10.0 ±0.3	10.0 ±0.3	4.8 Max.	4.6 ±0.2	1.97 ±0.3	5.8	4.9	10.8

• You can also contact us by e-mail : coilmaster@coilmaster.com
 • All specifications are subject to change without notice.
 • Update date : 2024.10.10

Regulation of part number

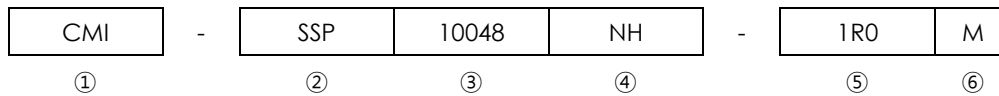

- ① CoilMaster's initial
- ② Series Name : Shielded core Square shape Pin type Power Inductor
- ③ Core Size (unit:mm)
- ④ Type
- ⑤ Typical inductance value (1.0uH)
- ⑥ Inductance tolerance ($\pm 20\%$)

Specifications

Part Number	Inductance (uH)	Tolerance (\pm)	DCR (mohm) Max.(Typ.)	Isat(A) Max.(Typ.)	Itemp(A) Max.(Typ.)	Test Frequency (Hz)
CMI-SSP10048NH-1R0M	1.0	20%	14.4(12.0)	14.30(14.50)	10.80(11.00)	100k
CMI-SSP10048NH-1R8M	1.8	20%	15.6(13.0)	11.00(11.50)	10.40(10.80)	100k
CMI-SSP10048NH-2R2M	2.2	20%	18.6(15.5)	9.50(9.70)	9.20(9.50)	100k
CMI-SSP10048NH-3R3M	3.3	20%	21.6(18.0)	9.40(9.60)	8.00(8.40)	100k
CMI-SSP10048NH-4R7M	4.7	20%	26.4(22.0)	8.00(8.13)	7.50(7.70)	100k
CMI-SSP10048NH-6R8M	6.8	20%	30.0(25.0)	5.90(6.10)	4.80(5.00)	100k
CMI-SSP10048NH-150M	15	20%	54.0(45.0)	4.65(4.75)	4.30(4.60)	100k
CMI-SSP10048NH-220M	22	20%	79.2(66.0)	3.95(4.05)	3.90(4.20)	100k
CMI-SSP10048NH-330M	33	20%	120(100)	3.20(3.30)	3.10(3.30)	100k
CMI-SSP10048NH-470M	47	20%	153(128)	2.70(2.80)	2.70(2.90)	100k
CMI-SSP10048NH-680M	68	20%	210(175)	2.10(2.20)	2.30(2.50)	100k
CMI-SSP10048NH-101M	100	20%	326(272)	1.80(1.85)	1.80(2.00)	100k
CMI-SSP10048NH-221M	220	20%	648(540)	1.10(1.20)	1.10(1.25)	100k
CMI-SSP10048NH-271M	270	20%	996(830)	1.00(1.10)	1.05(1.15)	100k
CMI-SSP10048NH-331M	330	20%	1020(850)	0.90(1.00)	0.95(1.05)	100k
CMI-SSP10048NH-102M	1000	20%	3024(2750)	0.55(0.60)	0.90(1.00)	100k

- Isat: When based on the inductance change rate (Approximately 30% below in the initial value)
- Itemp: When based on the temperature increase (Temperature increase of approximately 40°C by self heating)
- Operating Temperature Range (including self temperature) : -40°C ~ +125 °c

Note 1 : Circuit design, component placement, PCB trace size and thickness, airflow and other cooling. Provision all affect the part Temperature. Part temperature should be verified in the end application.

▪ **You can also contact us by e-mail : coilmaster@coilmaster.com**

- All specifications are subject to change without notice.
- Update date : 2024.10.10

www.coilmaster.com

Electrical characteristics

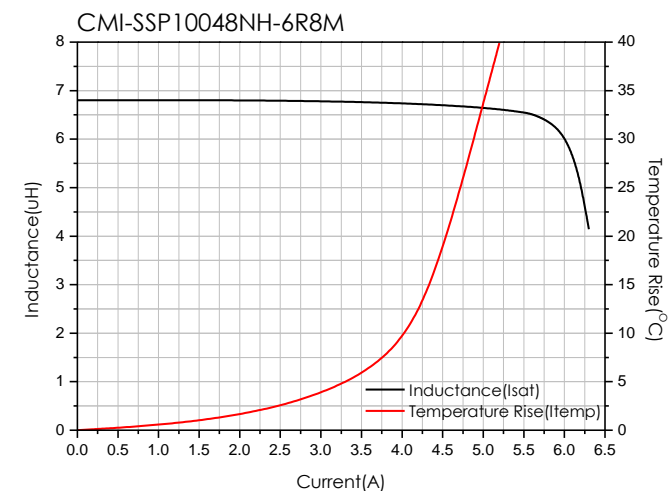
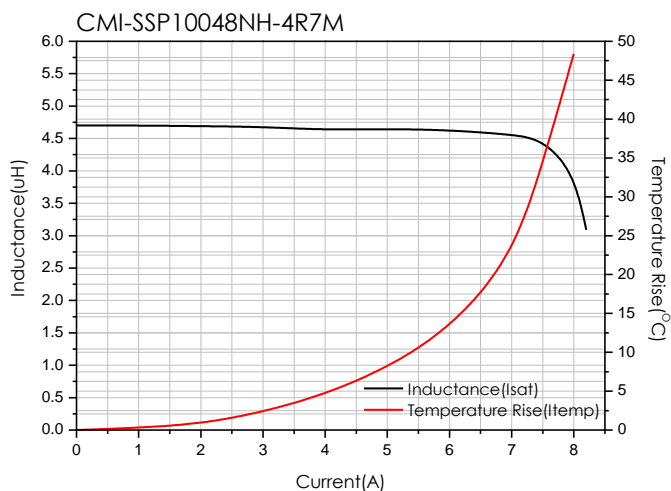
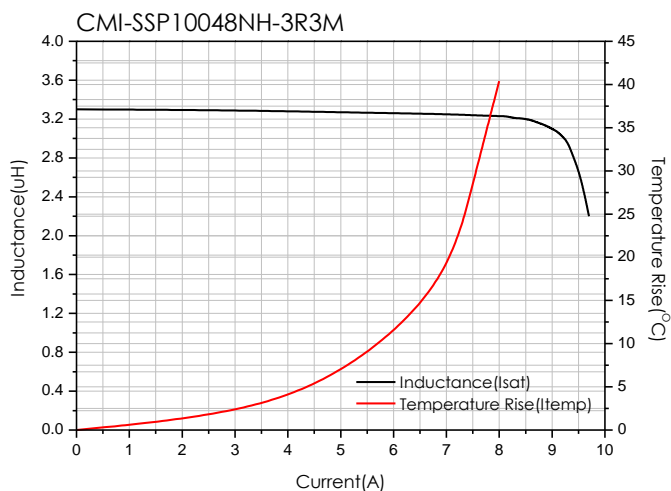
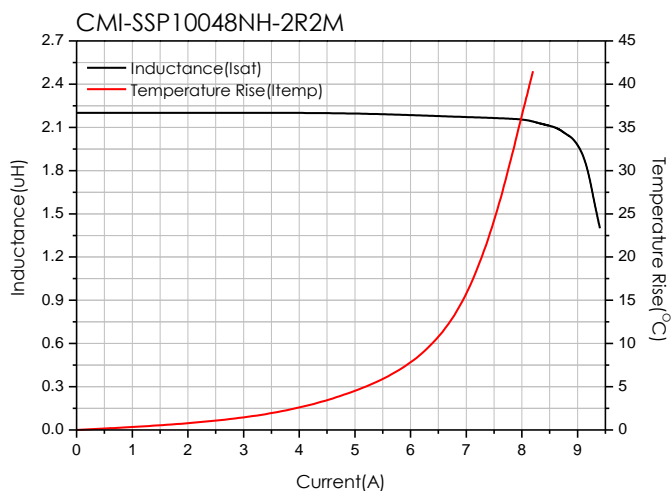
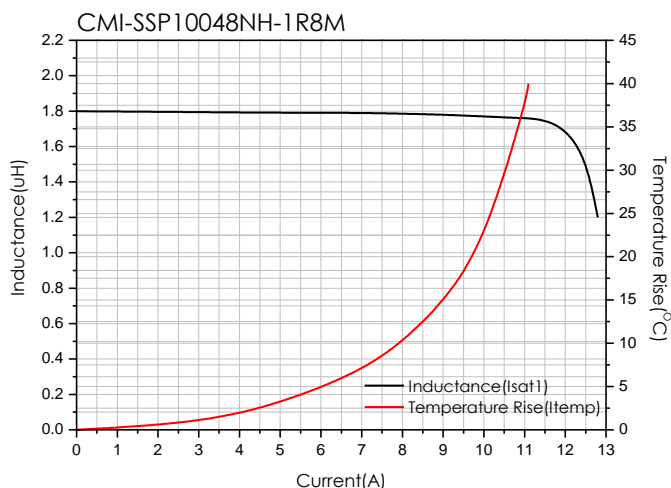
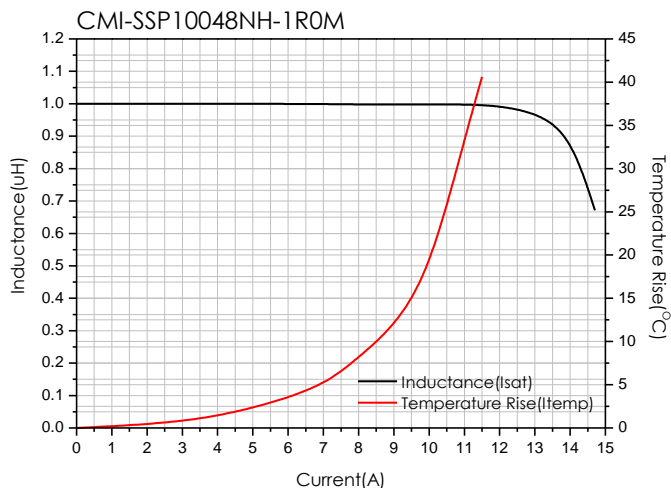

- You can also contact us by e-mail : coilmaster@coilmaster.com
- All specifications are subject to change without notice.
- Update date : 2024.10.10

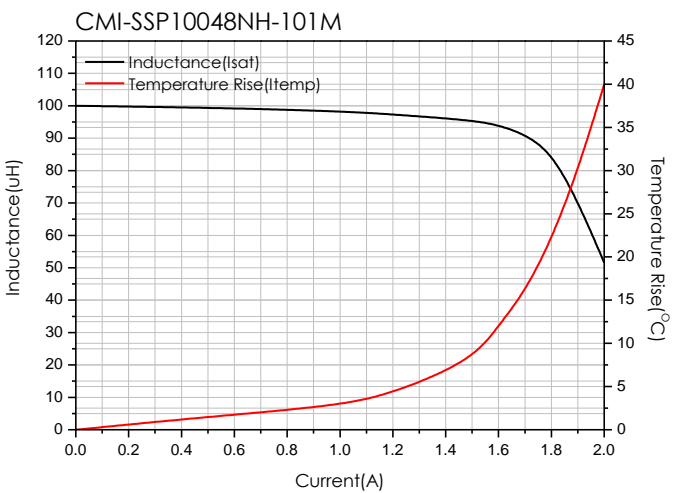
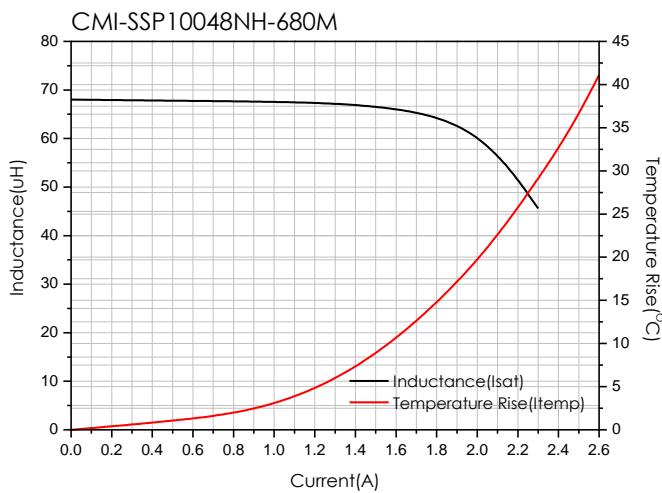
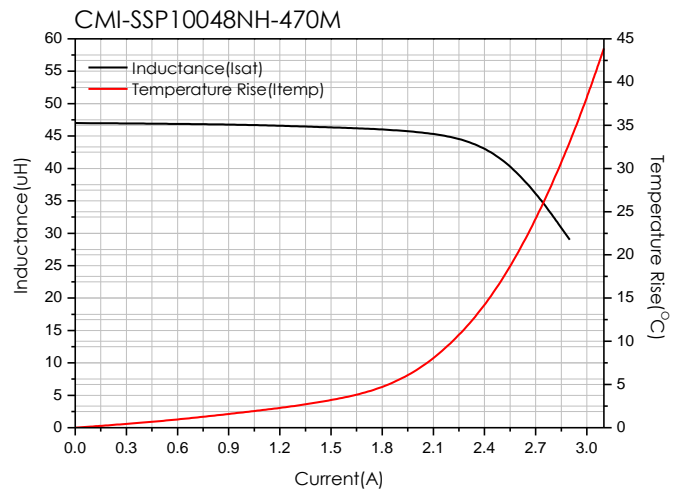
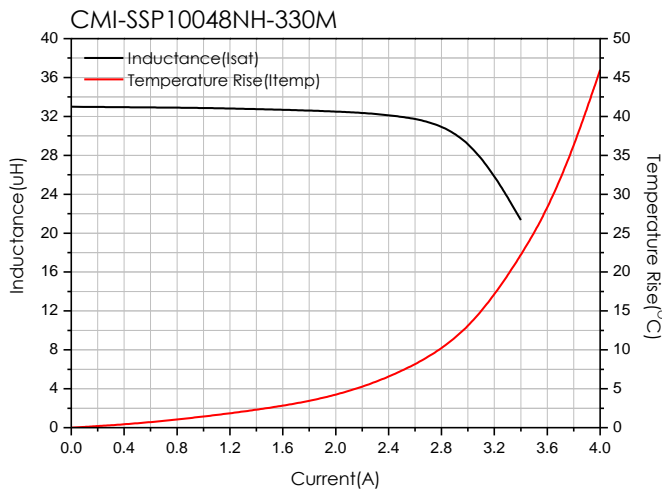
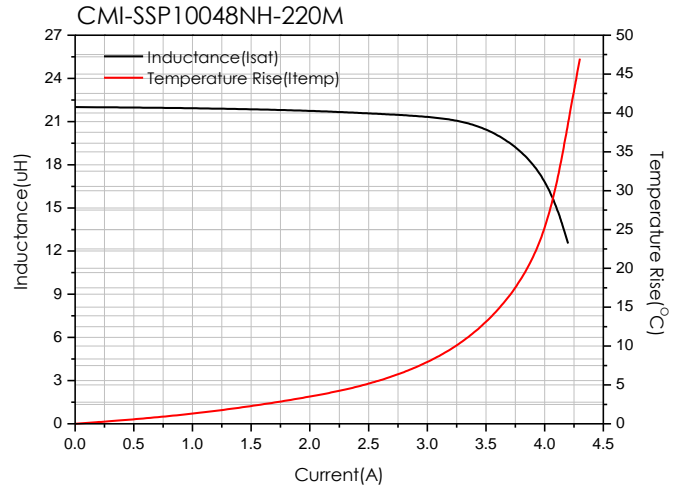
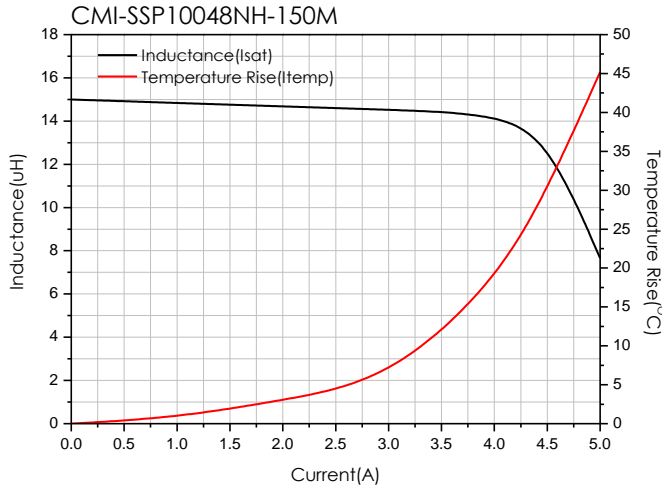

- You can also contact us by e-mail : coilmaster@coilmaster.com
- All specifications are subject to change without notice.
- Update date : 2024.10.10

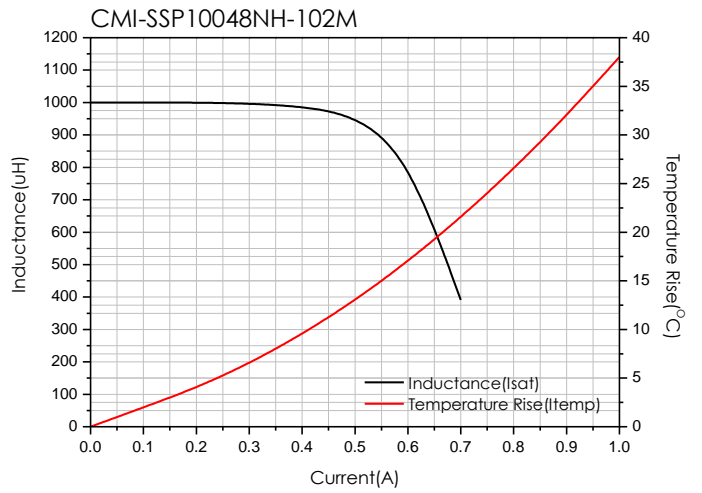
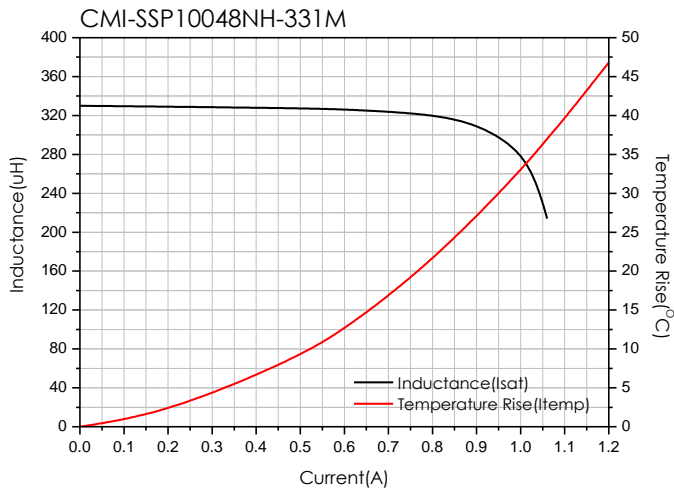
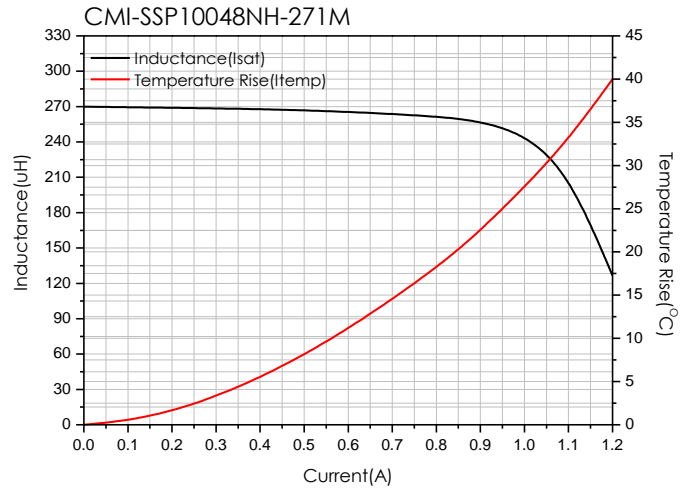
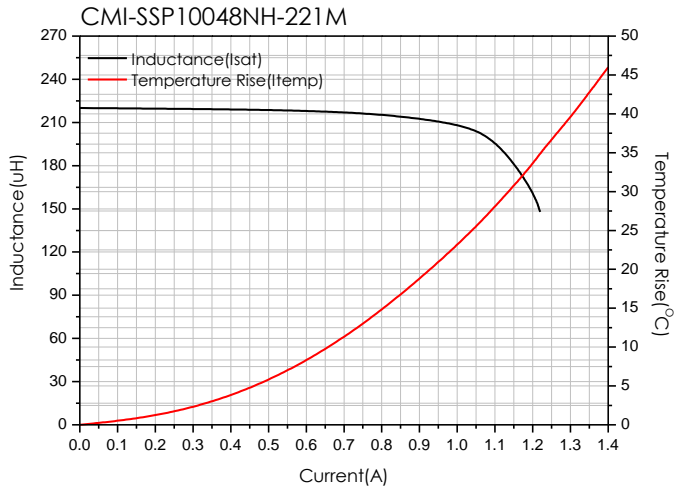

- You can also contact us by e-mail : coilmaster@coilmaster.com
- All specifications are subject to change without notice.
- Update date : 2024.10.10

Packaging

(1) Package quantity : 600 (pcs/reel)

(2) Reel Dimensions (unit:mm)

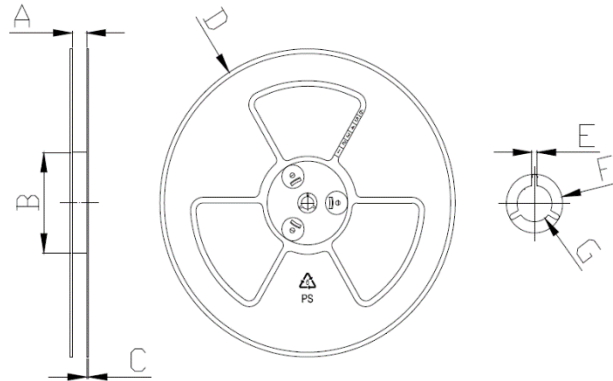

A	B	C	D	E	F	G
24.50	100.0	2.30	330.0	2.30	21.50	13.00
+0.50	+1.00	+0.20	+3.00	+0.30	+0.20	+0.40
-0.50	-1.00	-0.20	-3.00	-0.30	-0.20	-0.40

(3) Tape Dimensions

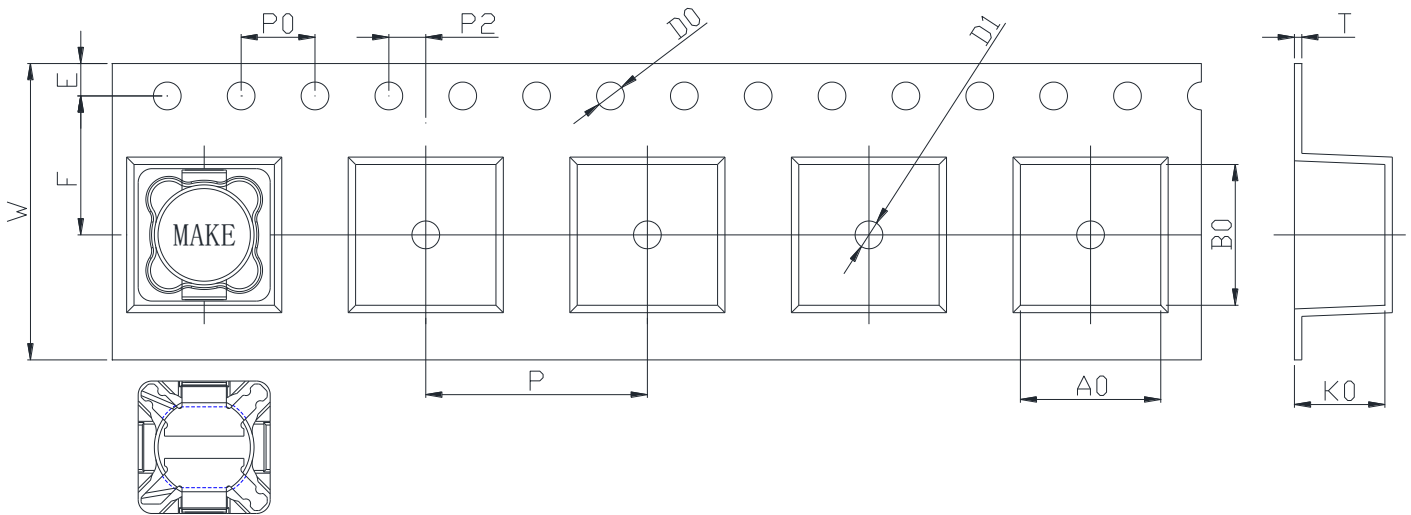

W	A0	B0	K0	E	F	P	P0	P2	D0/D1	T
24.00	10.50	10.50	4.90	1.75	11.50	16.00	4.00	2.00	1.50	0.40
+0.30	+0.10	+0.10	+0.10	+0.10	+0.10	+0.10	+0.10	+0.10	+0.10	+0.05
-0.10	-0.10	-0.10	-0.10	-0.10	-0.10	-0.10	-0.10	-0.10	-0.00	-0.05

Korea Sales Office (KOREA) +82)31-904-1444
 China Sales Office (CHINA) +86)0758-683-1444
 Hungary Sales office (EUROPE) +36)1-404-5832

H.K Sales Office (HONGKONG) +852)2711-5551
 LA Sales Office (USA) +1)714-616-6989

• You can also contact us by e-mail : coilmaster@coilmaster.com

- All specifications are subject to change without notice.
- Update date : 2024.10.10

www.coilmaster.com