

# CMI-SSP12080NH-SERIES

## Features

- ▶ SMD Inductor.
- ▶ Magnetic shield type wound inductor for power circuits.
- ▶ Available tape and reel for auto insertion.
- ▶ RoHs compliant.
- ▶ Halogen Free.

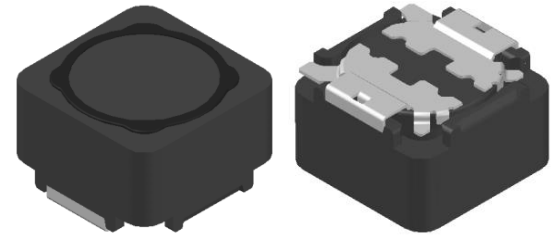

## Applications

- ▶ For small DC/DC converter (LCD/LED/OLED TV, PC, SETTOP etc)
- ▶ For Power supply circuits

## Dimension (Unit:mm)

## Land Pattern (Unit:mm)

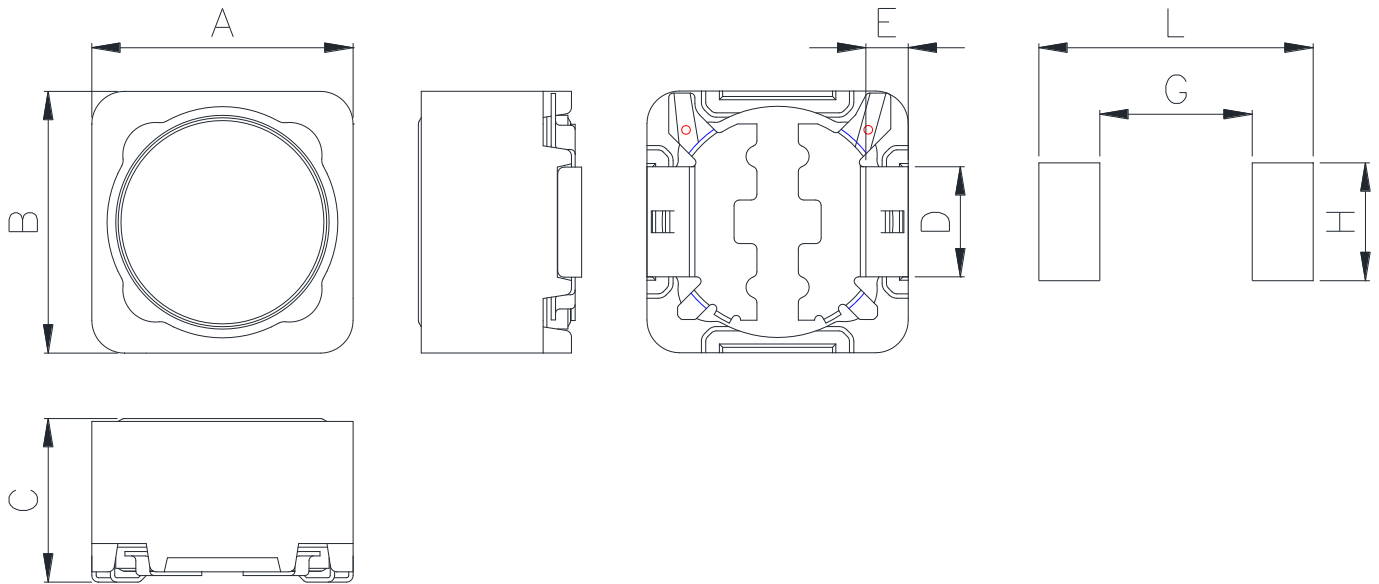

A	B	C	D	E	G	H	L
12.0 ±0.3	12.0 ±0.3	8.0 Max.	5.0 ±0.2	1.9 ±0.3	7.0	5.4	12.6

## Regulation of part number

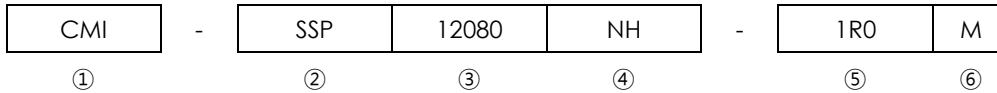

- ① CoilMaster's initial
- ② Series Name : Shielded core Square shape Pin type Power Inductor
- ③ Core Size (unit:mm)
- ④ Type
- ⑤ Typical inductance value (1.0uH)
- ⑥ Inductance tolerance ( $\pm 20\%$ )

## Specifications

Part Number	Inductance (uH)	Tolerance ( $\pm$ )	DCR (mohm) Max.(Typ.)	Isat(A) Max.(Typ.)	Itemp(A) Max.(Typ.)	Test Frequency (Hz)
CMI-SSP12080NH-1R0M	1.0	20%	10.1(7)	18.00(20.00)	16.00(17.00)	100k
CMI-SSP12080NH-1R2M	1.2	20%	11(8.5)	15.50(16.00)	13.00(13.50)	100k
CMI-SSP12080NH-2R2M	2.2	20%	11.7(9)	11.50(12.00)	12.00(12.50)	100k
CMI-SSP12080NH-3R9M	3.9	20%	15.6(13)	11.00(11.50)	9.80(10.20)	100k
CMI-SSP12080NH-4R7M	4.7	20%	16.8(14)	10.50(11.00)	9.30(9.70)	100k
CMI-SSP12080NH-6R8M	6.8	20%	25.2(16)	10.00(10.50)	9.20(9.60)	100k
CMI-SSP12080NH-8R2M	8.2	20%	21.6(18)	9.00(9.50)	8.80(9.10)	100k
CMI-SSP12080NH-100M	10	20%	24(20)	8.70(9.20)	8.50(8.90)	100k
CMI-SSP12080NH-150M	15	20%	38(32)	6.90(7.20)	6.80(7.10)	100k
CMI-SSP12080NH-220M	22	20%	42(35)	5.30(5.60)	5.50(5.90)	100k
CMI-SSP12080NH-250M	25	20%	50.4(42)	5.20(5.50)	5.30(5.70)	100k
CMI-SSP12080NH-330M	33	20%	54(45)	4.50(4.80)	4.80(5.30)	100k
CMI-SSP12080NH-450M	45	20%	69.6(58)	4.30(4.60)	4.60(4.90)	100k
CMI-SSP12080NH-470M	47	20%	72(60)	3.60(3.90)	4.40(4.70)	100k
CMI-SSP12080NH-560M	56	20%	84(70)	3.50(3.80)	4.00(4.30)	100k
CMI-SSP12080NH-680M	68	20%	90(80)	3.20(3.50)	3.50(3.90)	100k
CMI-SSP12080NH-820M	82	20%	80.4(67)	3.00(3.30)	3.40(3.70)	100k
CMI-SSP12080NH-101M	100	20%	150(125)	2.80(3.00)	3.30(3.60)	100k
CMI-SSP12080NH-121M	120	20%	168(140)	2.60(2.80)	2.90(3.20)	100k
CMI-SSP12080NH-151M	150	20%	276(230)	2.30(2.40)	2.40(2.60)	100k

• You can also contact us by e-mail : [coilmaster@coilmaster.com](mailto:coilmaster@coilmaster.com)

- All specifications are subject to change without notice.
- Update date : 2024.04.30



# Electrical characteristics

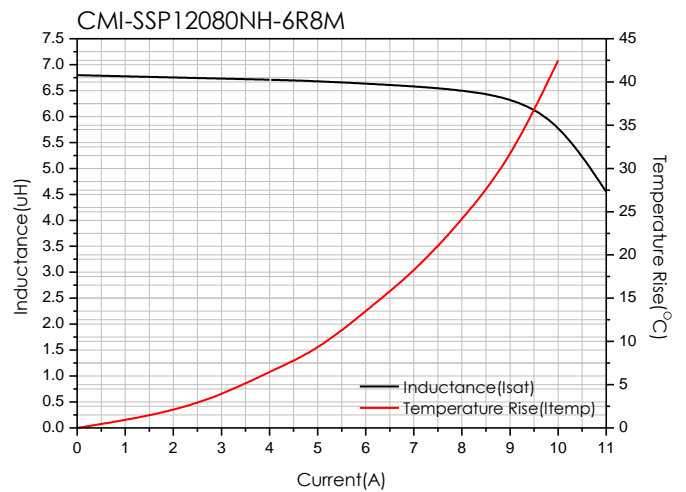
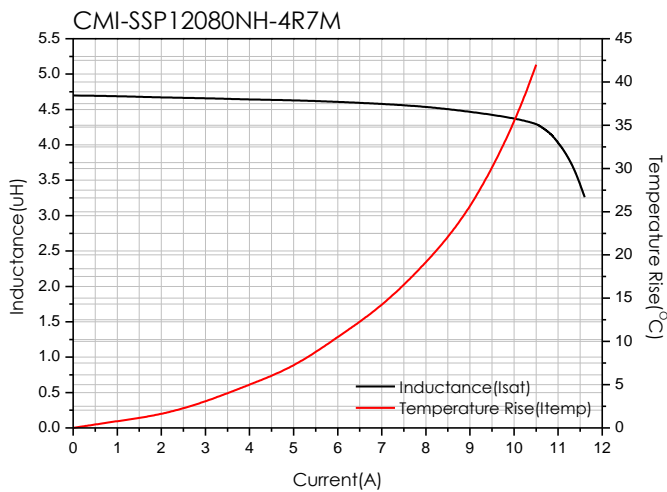
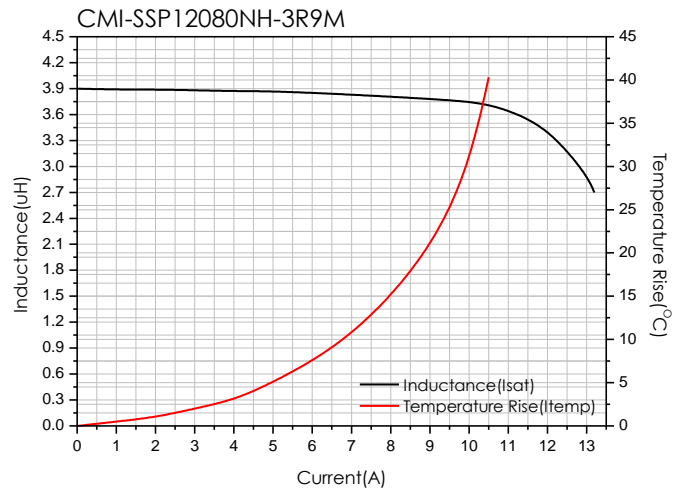
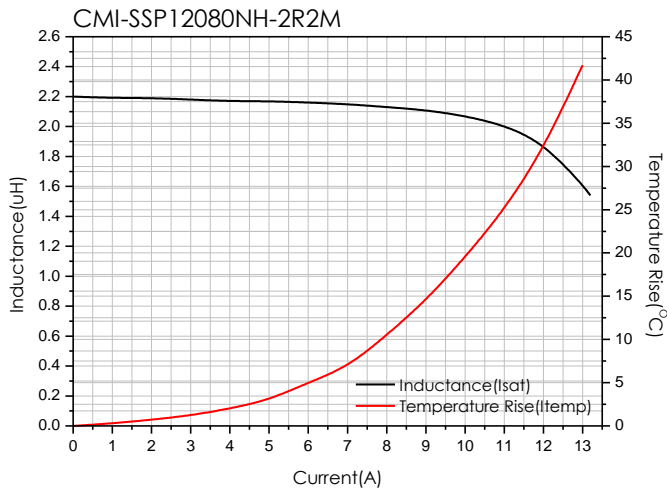
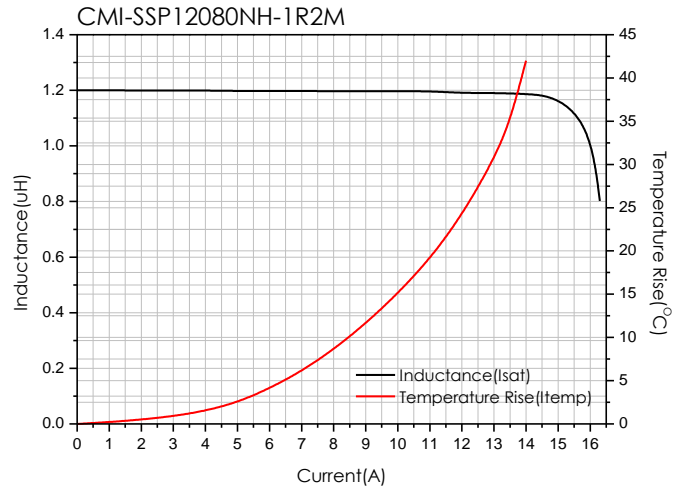
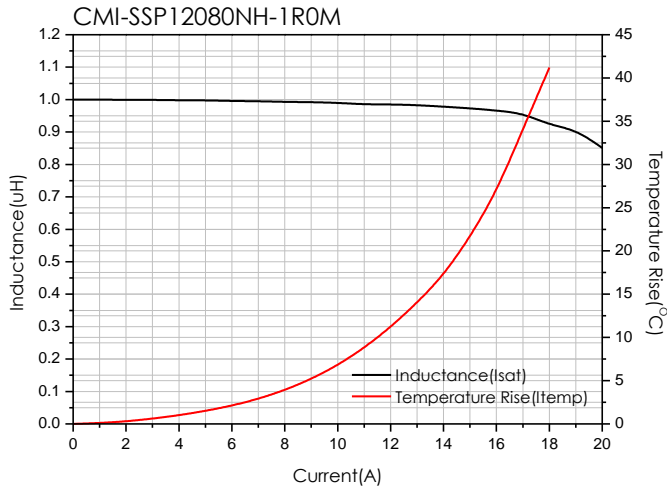

- You can also contact us by e-mail : [coilmaster@coilmaster.com](mailto:coilmaster@coilmaster.com)
- All specifications are subject to change without notice.
- Update date : 2024.04.30

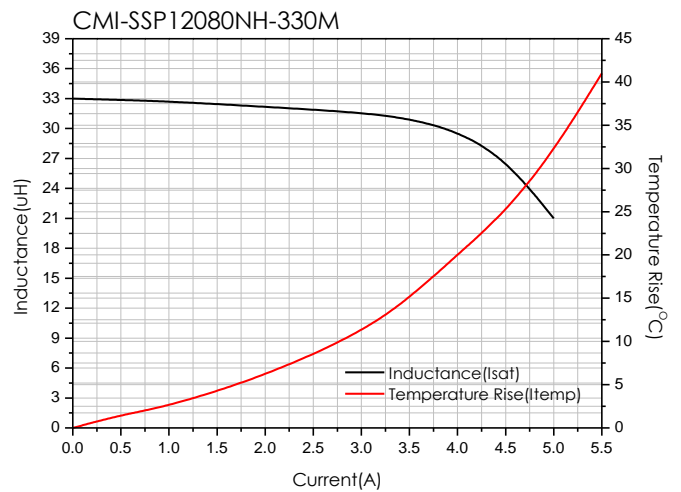
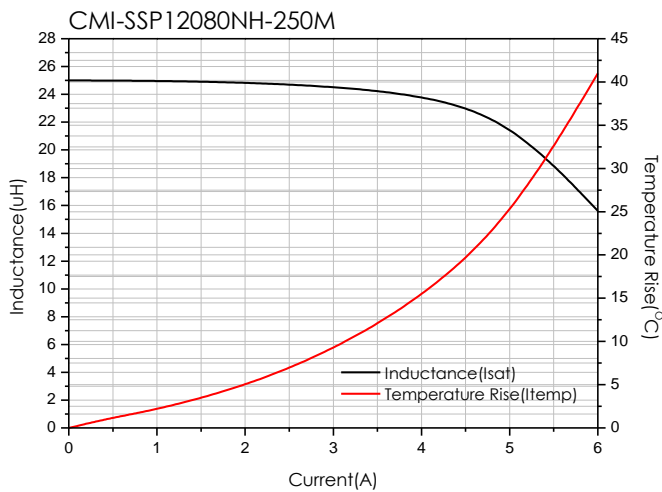
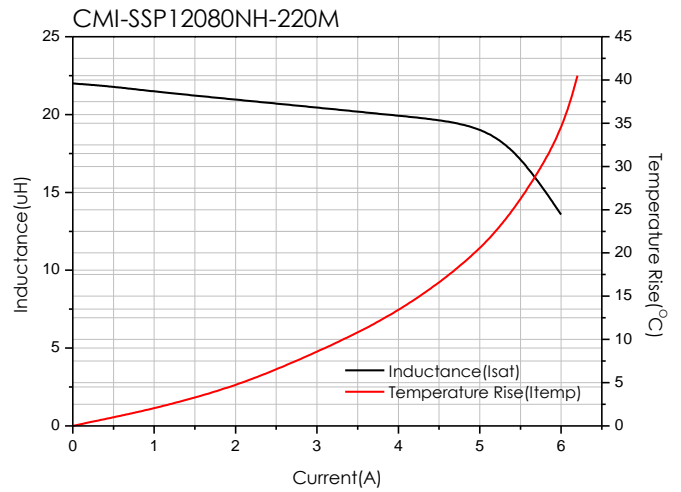
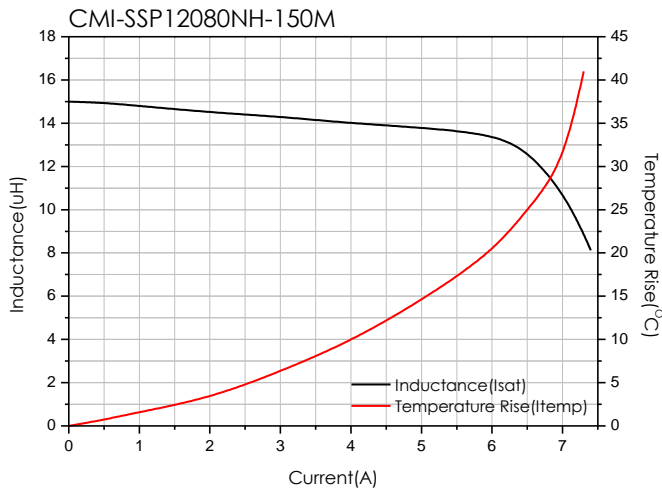
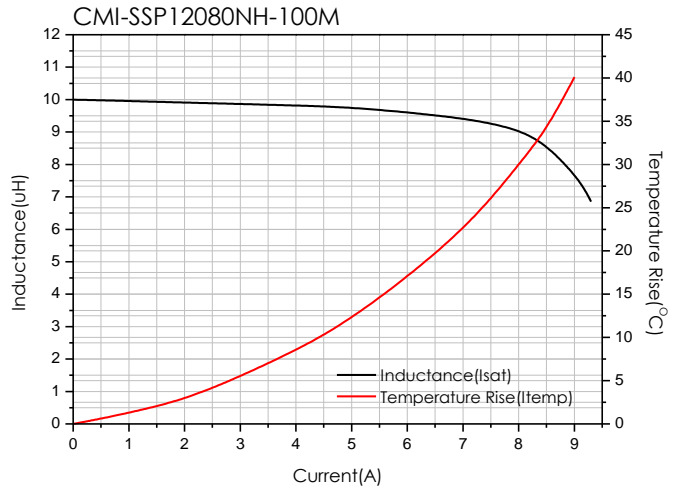
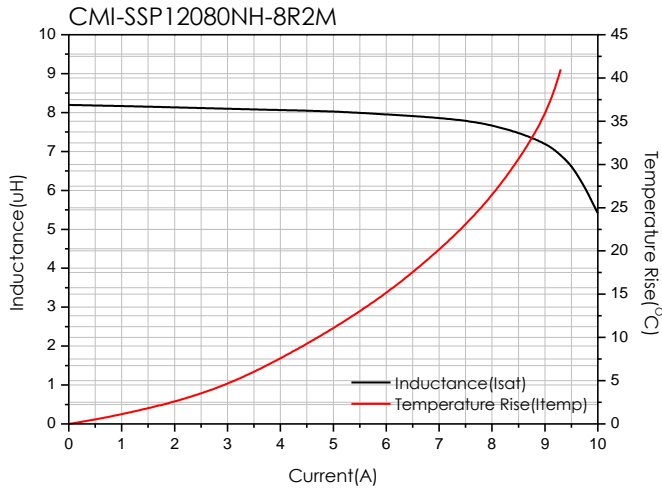

- You can also contact us by e-mail : [coilmaster@coilmaster.com](mailto:coilmaster@coilmaster.com)
- All specifications are subject to change without notice.
- Update date : 2024.04.30

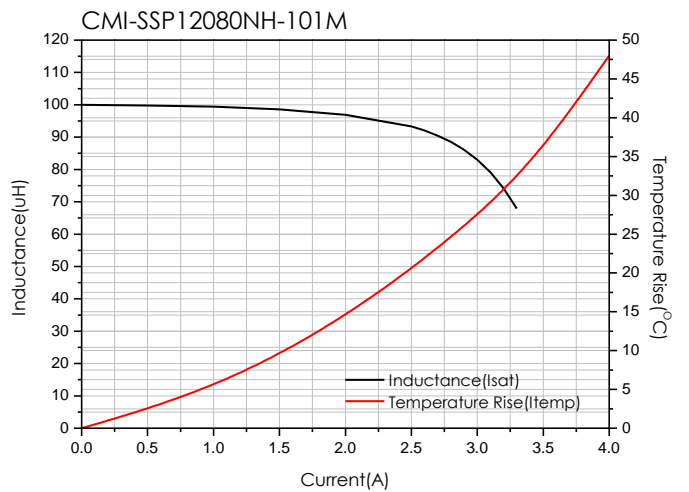
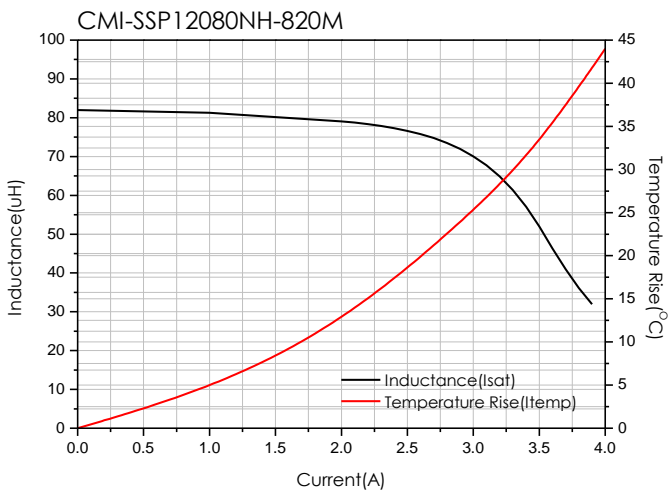
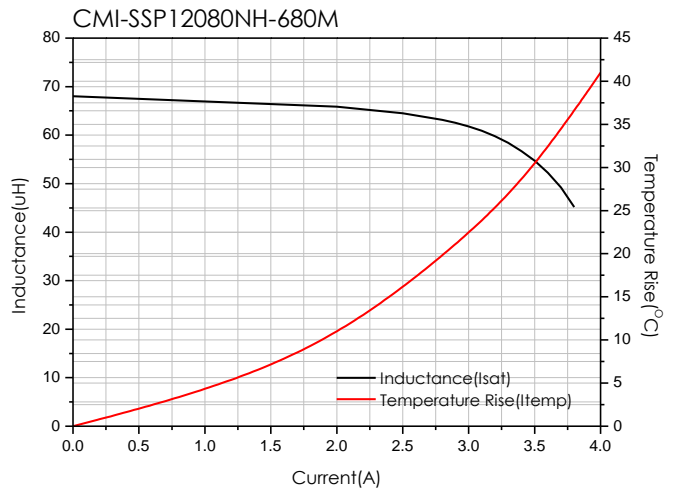
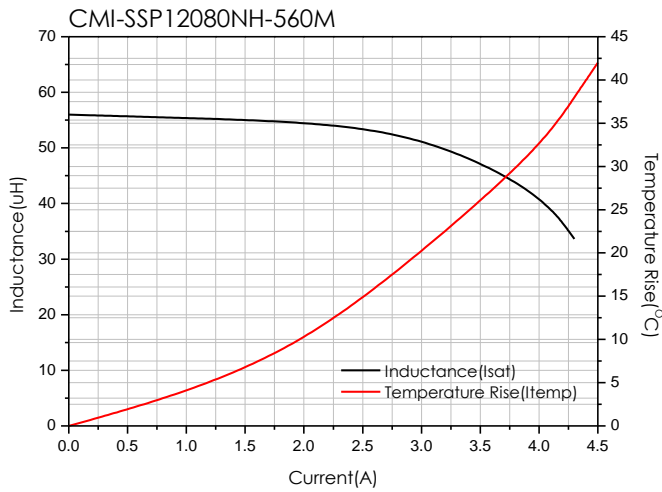
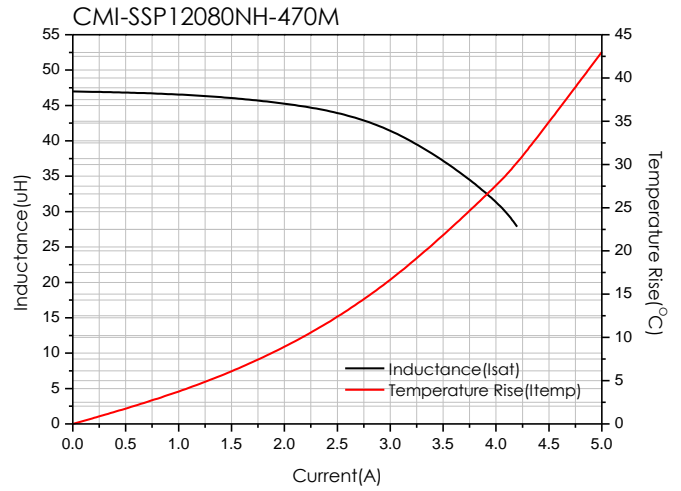
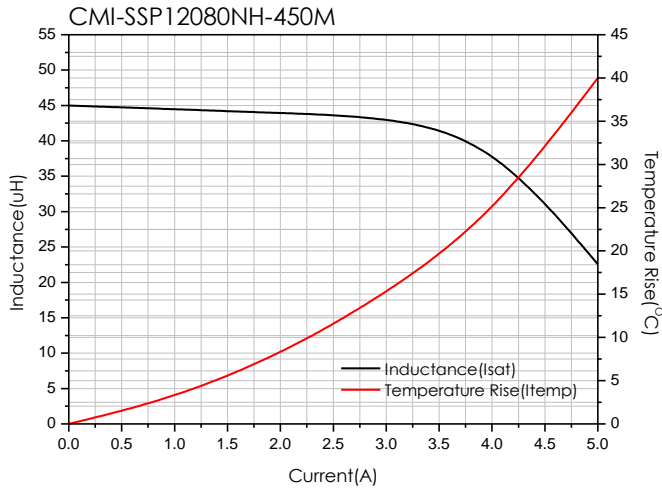

- You can also contact us by e-mail : [coilmaster@coilmaster.com](mailto:coilmaster@coilmaster.com)
- All specifications are subject to change without notice.
- Update date : 2024.04.30

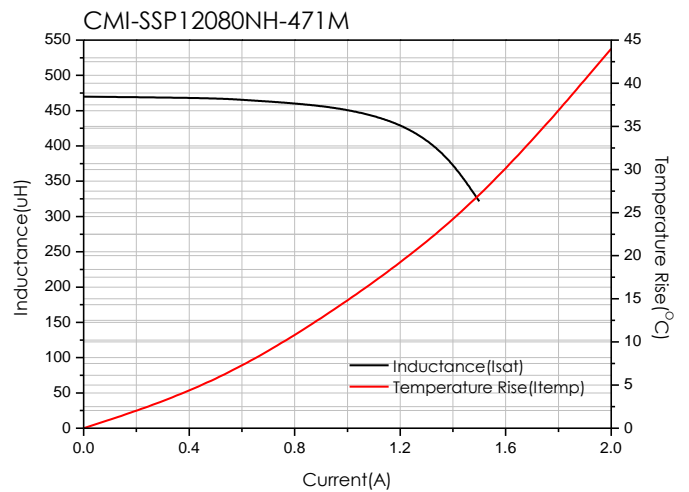
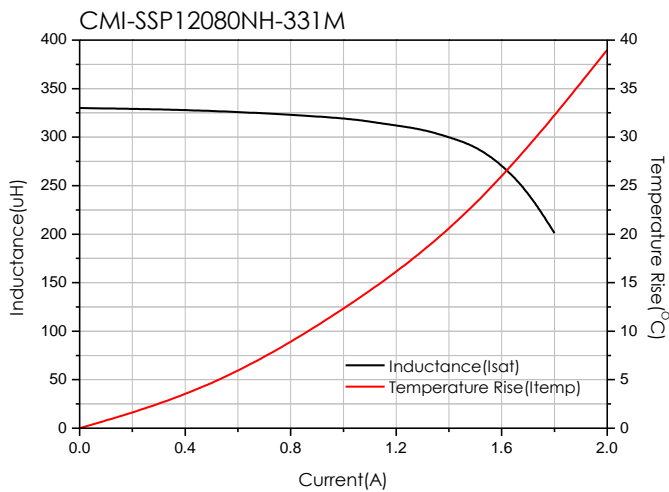
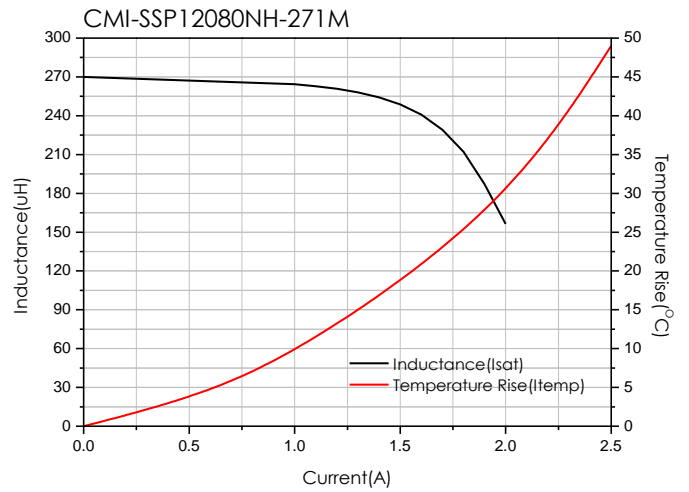
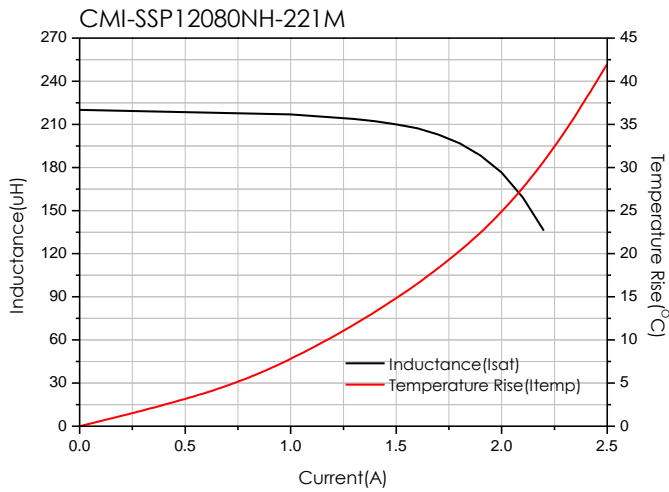
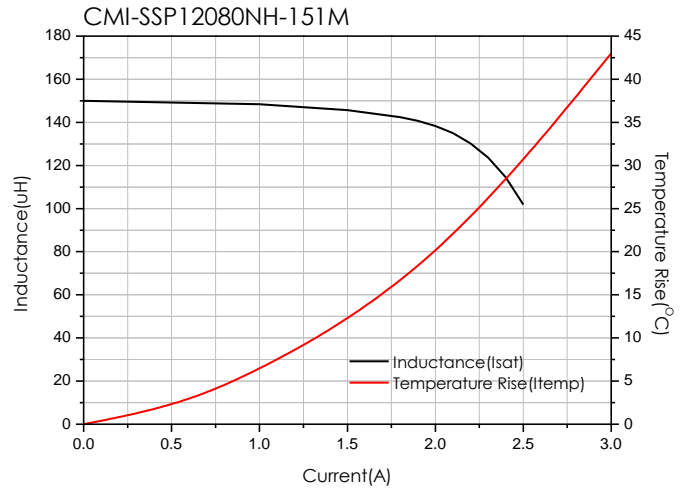
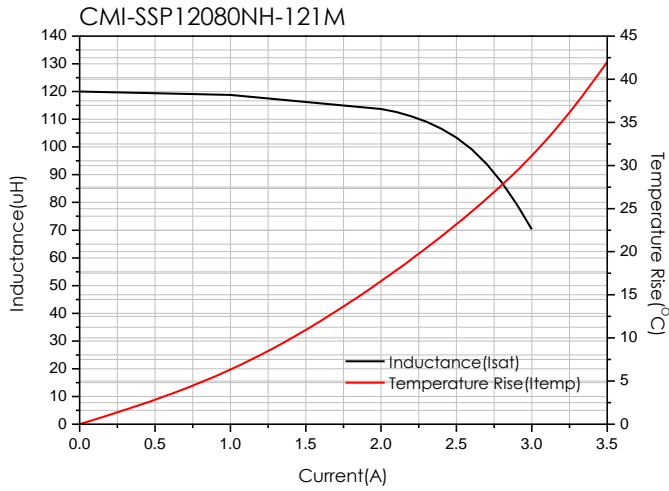

- You can also contact us by e-mail : [coilmaster@coilmaster.com](mailto:coilmaster@coilmaster.com)
- All specifications are subject to change without notice.
- Update date : 2024.04.30

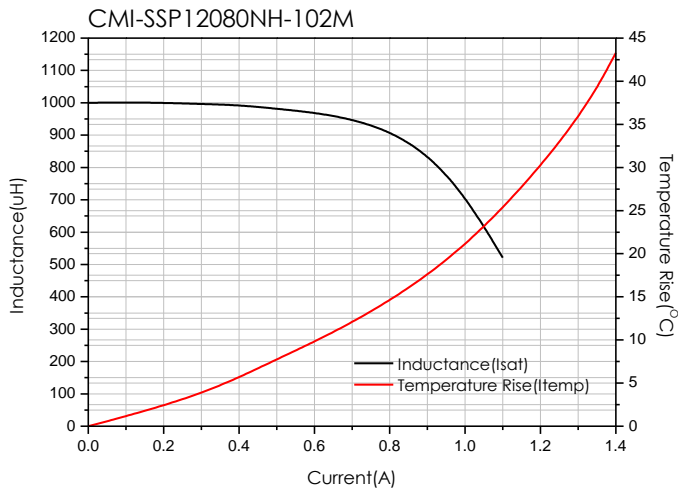
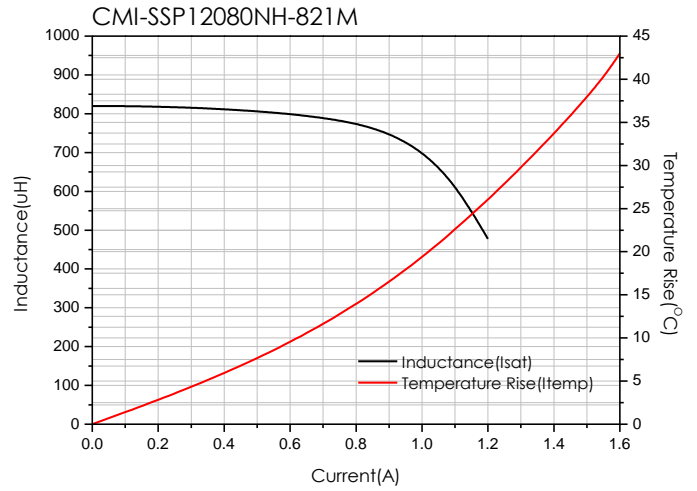
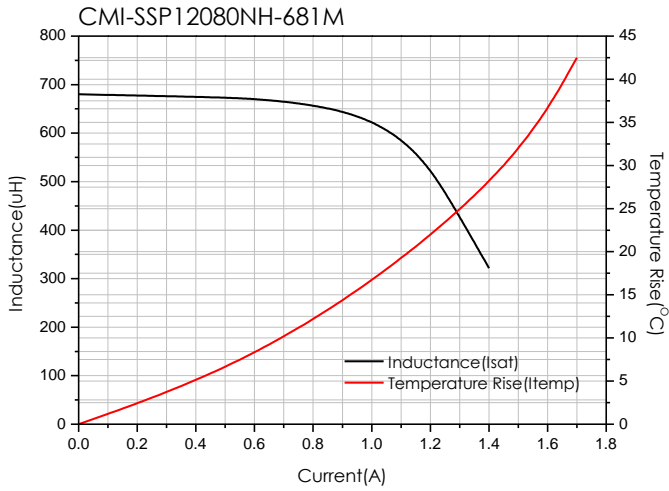

- You can also contact us by e-mail : [coilmaster@coilmaster.com](mailto:coilmaster@coilmaster.com)
- All specifications are subject to change without notice.
- Update date : 2024.04.30



## Packaging

(1) Package quantity : 500 (pcs/reel)

(2) Reel Dimensions (unit:mm)

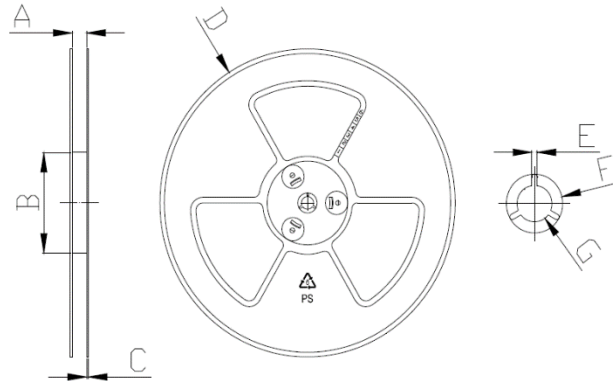

A	B	C	D	E	F	G
24.50	100.0	2.30	330.0	2.30	21.50	13.00
+0.50	+1.00	+0.20	+3.00	+0.30	+0.20	+0.40
-0.50	-1.00	-0.20	-3.00	-0.30	-0.20	-0.40

(3) Tape Dimensions

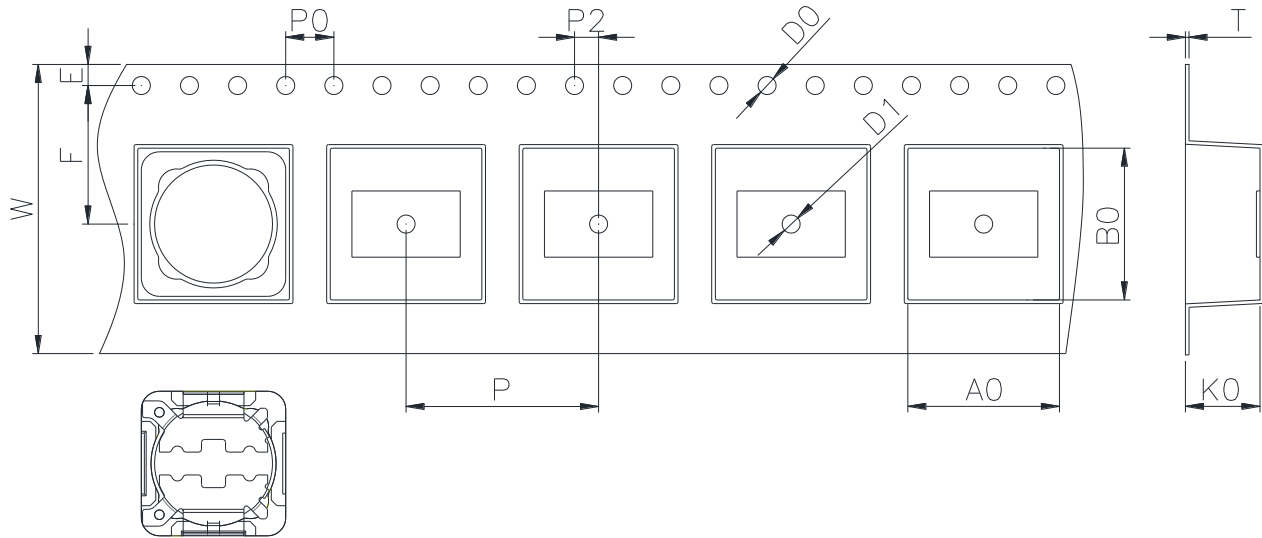

W	A0	B0	K0	E	F	P	P0	P2	D0/D1	T
24.00	12.60	12.60	8.30	1.75	11.50	16.00	4.00	2.00	1.50	0.40
+0.30	+0.10	+0.10	+0.10	+0.10	+0.10	+0.10	+0.10	+0.10	+0.10	+0.05
-0.10	-0.10	-0.10	-0.10	-0.10	-0.10	-0.10	-0.10	-0.10	-0.00	-0.05

Korea Sales Office (KOREA) +82)31-904-1444  
 China Sales Office (CHINA) +86)0758-683-1444  
 Hungary Sales office (EUROPE) +36)1-404-5832

H.K Sales Office (HONGKONG) +852)2711-5551  
 LA Sales Office (USA) +1)714-616-6989

• You can also contact us by e-mail : [coilmaster@coilmaster.com](mailto:coilmaster@coilmaster.com)

- All specifications are subject to change without notice.
- Update date : 2024.04.30

[www.coilmaster.com](http://www.coilmaster.com)