

CMI-SSP8045NH-A SERIES

Features

- ▶ SMD inductor
- ▶ It corresponds to High current.
- ▶ Simple and Shield structure.
- ▶ Available tape and reel for auto insertion.
- ▶ RoHS compliant.
- ▶ Halogen Free.

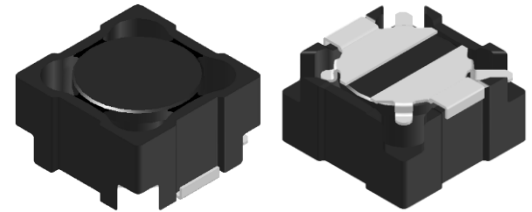

Applications

- ▶ For small DC/DC converter (LCD/LED/OLED TV, PC, SETTOP etc).
- ▶ For Power supply circuits.

Dimension (Unit:mm)

Land Pattern (Unit:mm)

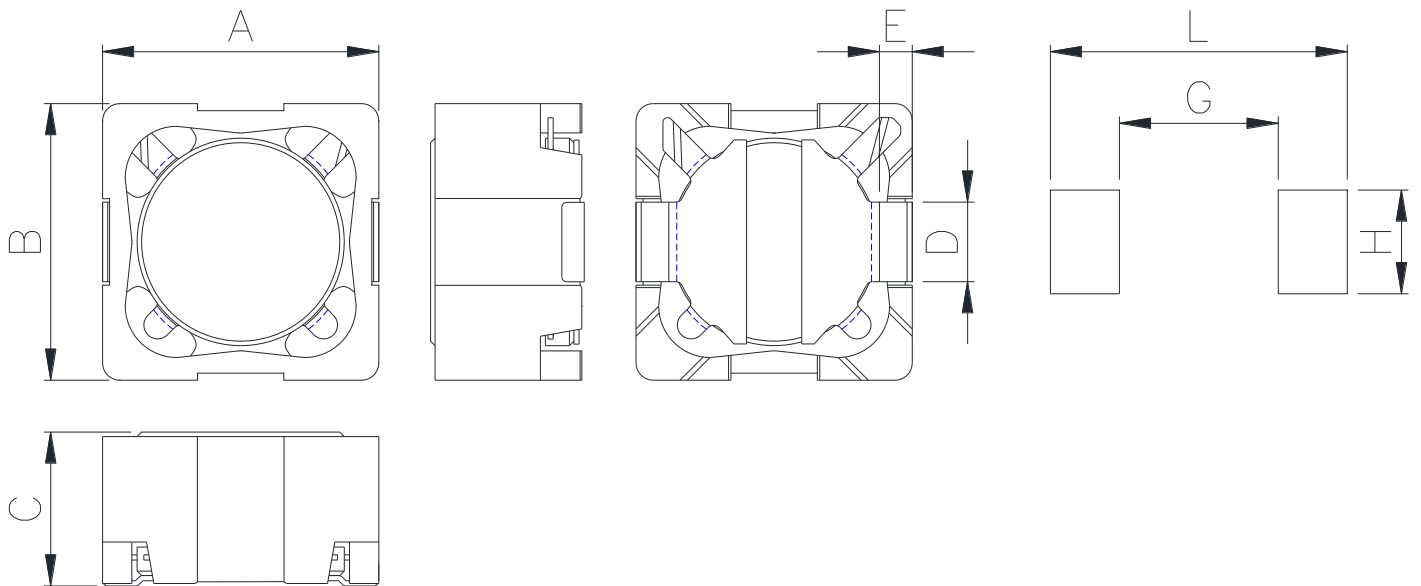

A	B	C	D	E	G	H	L
8.0 ±0.3	8.0 ±0.3	4.5 Max.	2.3 ±0.2	1.0 ±0.2	4.6	3.0	8.6

Regulation of part number

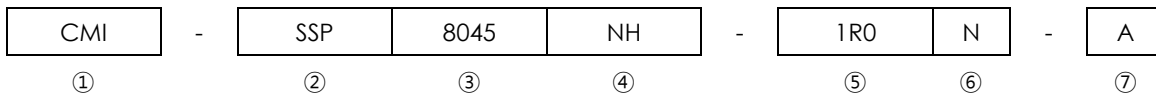

- ① CoilMaster's initial
- ② Series Name : Car Shielded core Square shape Pin type Power Inductor
- ③ Core Size (unit:mm)
- ④ Type
- ⑤ Typical inductance value (1.0uH)
- ⑥ Inductance tolerance (±30%)
- ⑦ Revision (A)

Specifications

Part Number	Inductance (uH)	Tolerance (±)	DCR (mohm) Max.(Typ.)	Isat(A) Max.	Itemp(A) Max.	Test Frequency (Hz)
CMI-SSP8045NH-1R0N-A	1.0	30%	19.2(16)	6.50		100k
CMI-SSP8045NH-3R3N-A	3.3	30%	32.4(27)	6.00		100k
CMI-SSP8045NH-4R7N-A	4.7	30%	39.6(33)	5.30		100k
CMI-SSP8045NH-6R8N-A	6.8	30%	54(45)	4.50		100k
CMI-SSP8045NH-100M-A	10	20%	74.4(62)	4.00		100k
CMI-SSP8045NH-150M-A	15	20%	90(75)	3.60		100k
CMI-SSP8045NH-220M-A	22	20%	111.6(93)	3.00		100k
CMI-SSP8045NH-330M-A	33	20%	164.4(137)	2.30		100k
CMI-SSP8045NH-470M-A	47	20%	232.8(194)	2.00		100k
CMI-SSP8045NH-680M-A	68	20%	343.2(286)	1.70		100k
CMI-SSP8045NH-101M-A	100	20%	498(415)	1.40		100k
CMI-SSP8045NH-221M-A	220	20%	1149.6(958)	1.00		100k

- Isat: When based on the inductance change rate (Approximately 20% below in the initial value)
- Itemp: When based on the temperature increase (Temperature increase of approximately 40°C by self heating)
- Operating Temperature Range (including self temperature) : -40°C ~ +125 °c

Note 1 : Circuit design, component placement, PCB trace size and thickness, airflow and other cooling. Provision all affect the part Temperature. Part temperature should be verified in the end application.

▪ **You can also contact us by e-mail : coilmaster@coilmaster.com**

- All specifications are subject to change without notice.
- Update date : 2021.10.26

www.coilmaster.com

Packaging

(1) Package quantity : 1,000 (pcs/reel)

(2) Reel Dimensions (unit:mm)

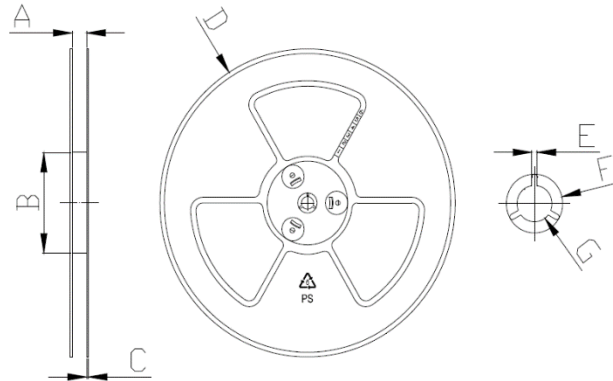

A	B	C	D	E	F	G
16.50	100.0	2.00	330.0	2.30	21.50	13.00
+0.50	+1.00	+0.10	+3.00	+0.30	+0.30	+0.50
-0.50	-1.00	-0.10	-3.00	-0.30	-0.30	-0.20

(3) Tape Dimensions

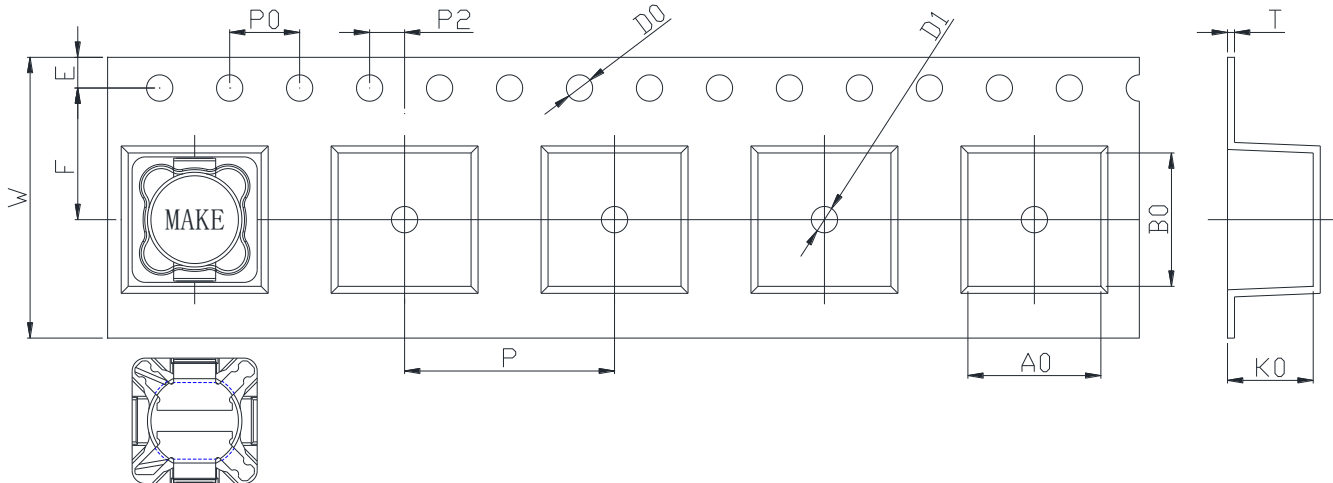

W	A0	B0	K0	E	F	P	P0	P2	D0/D1	T
16.00	8.30	8.30	4.70	1.75	7.50	12.00	4.00	2.00	1.50	0.40
+0.30	+0.10	+0.10	+0.10	+0.10	+0.10	+0.10	+0.10	+0.10	+0.10	+0.05
-0.30	-0.10	-0.10	-0.10	-0.10	-0.10	-0.10	-0.10	-0.10	-0.00	-0.05

Korea Sales Office (KOREA) +82)31-904-1444
 China Sales Office (CHINA) +86)0758-683-1444
 Hungary Sales office (EUROPE) +36)1-404-5832

H.K Sales Office (HONGKONG) +852)2711-5551
 LA Sales Office (USA) +1)714-616-6989

• You can also contact us by e-mail : coilmaster@coilmaster.com

- All specifications are subject to change without notice.
- Update date : 2021.10.26

www.coilmaster.com