

# CME-CSCF3225B-A SERIES

## Features

- ▶ High common mode impedance at high frequency effects  
Excellent noise suppression performance.
- ▶ Realizes small size and low profile.
- ▶ RoHS compliant.
- ▶ High reliability test meet AEC-Q200.

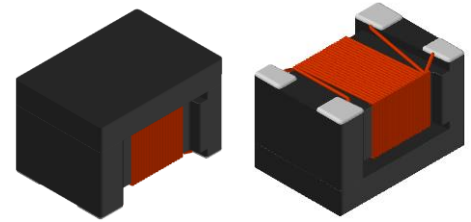

## Applications

- ▶ CAN-BUS, FAXs, modems, ISDNs, etc.

### Dimension (Unit:mm)

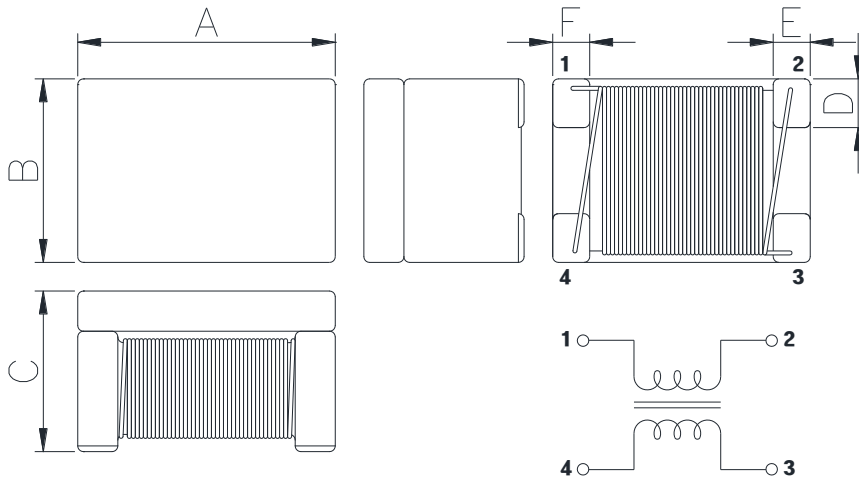

### Land Pattern (Unit:mm)

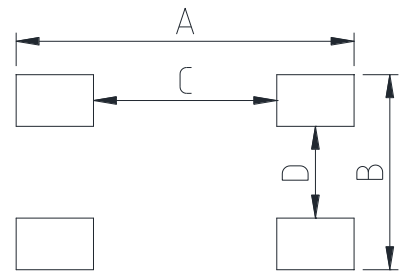

A	B	C	D	E	F
3.2±0.2	2.5±0.2	2.5 Max.	0.8±0.2	0.5±0.2	0.5±0.2

A	B	C	D
3.7	2.3	2.2	0.6

## Regulation of part number

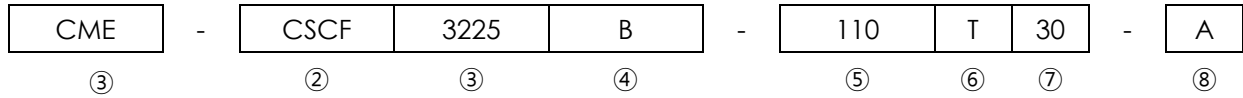

- ① CoilMaster's initial
- ② Series Name : Car Signal Line Common mode Filter
- ③ Core Size (unit:mm)
- ④ Type
- ⑤ Common mode inductance value (100 uH)
- ⑥ Packing type
- ⑦ Rated Current
- ⑧ Revision

## Specifications

Part Number	Common Mode Inductance (μH)	Common Mode Impedance (Ω) Min.(Typ.)	DCR (Ω) Max.	Rated Current (mA) Max.	Insulation Resistance (MΩ) Min.	Rated Voltage (V) Max.
CME-CSCF3225B-110T30-A	11	300(550)	0.4	300	10	80
CME-CSCF3225B-220T25-A	22	500(1100)	0.5	250	10	80
CME-CSCF3225B-510T20-A	51	1000(2600)	0.7	200	10	80
CME-CSCF3225B-101T15-A	100	2200(5100)	1.5	150	10	80

- Inductance test condition : 100 kHz ( L tolerance+50/-30% )
- Impedance test condition : 10 MHz
- Operating Temperature Range : -40 °c ~ +150 °c

---

Korea Sales Office (KOREA)	+82)31-904-1444	H.K Sales Office (HONGKONG)	+852)2711-5551
China Sales Office (CHINA)	+86)0758-683-1444	LA Sales Office (USA)	+1)714-616-6989
Hungary Sales office (EUROPE)	+36)1-404-5832		

▪ **You can also contact us by e-mail : [coilmaster@coilmaster.com](mailto:coilmaster@coilmaster.com)**

- All specifications are subject to change without notice.
- Update date : 2023.04.06

[www.coilmaster.com](http://www.coilmaster.com)